



TELEFLEX CANADA
3831 NO.6 ROAD
RICHMOND, B.C.
CANADA V6V 1P6

FAX 604-270-7172

www.seastarsteering.com

ISO 10592



© 1993 TELEFLEX CANADA LIMITED PARTNERSHIP

PRINTED IN CANADA

FORM NO. 070323 2000-04/03 Rev M

MEMBER
ABYC
Setting Standards for Safer Boating

2

T W O
ISO 9001

*BayStar*TM
*Capilano*TM
and
SeaStar[®]

ARE MANUFACTURED BY

IT **Teleflex**[®]
Teleflex Canada

INSTALLATION INSTRUCTIONS

AND OWNERS MANUAL

www.seastarsteering.com



SeaStar[®]

HYDRAULIC STEERING FOR INBOARD
& STERNDRIVE POWERED VESSELS



*Before you do it your way,
please try it our way*

Notice to Boat Manufacturer or Installer

Throughout this publication, Warnings and Cautions (accompanied by the International Hazard Symbol ) are used to alert the manufacturer or installer to special instructions concerning a particular service or operation that may be hazardous if performed incorrectly or carelessly.

Observe Them Carefully!

These “safety alerts” alone, cannot eliminate the hazards that they signal. Strict compliance to these special instructions when performing the installation and maintenance plus “common sense” operation are major accident prevention measures.

 DANGER	 WARNING	 CAUTION	NOTICE
Immediate hazards which WILL result in severe personal injury or death.	Hazards or unsafe practices which COULD result in severe personal injury or death.	Hazards or unsafe practices which COULD result in minor injury or product or property damage.	Information which is important to proper installation or maintenance, but is not hazard-related.

WARNING

Cleaning fluids containing ammonia, acids or any other corrosive ingredients MUST NOT be used for cleaning any part of this Hydraulic Steering System. Failure to comply will cause serious damage to the steering system, resulting in possible loss of steering, causing property damage, personal injury and/or death.

Introduction

The SeaStar helms are the smoothest and most efficient hydraulic steering systems available. They have been designed for normal pleasure and commercial boat use where standard rigging arrangements are used.

Before proceeding with the installation, read these instructions thoroughly. Teleflex cannot accept responsibility for installations where instructions have not been followed, where substitute parts have been used, or where modifications have been made to our products.

This precision built product may not function properly if dirt or contaminant's are introduced into the system.

NOTICE

Due to a small amount of internal oil slip, a "master spoke" or "centered" steering wheel cannot be maintained with a hydraulic steering system. For best results, use an equal distance spoke steering wheel.

Index

System Diagram	1
Tools	2
Mounting the Helm	3
Cylinder Mounting.....	8
Tubing Installation	13
Filling and Purging	16
Maintenance	20
Trouble Shooting Guide	20
Technical Information.....	23
Parts List.....	24
Statement of Limited Warranty	38
Return Goods Procedure	38

Typical Inboard Steering System

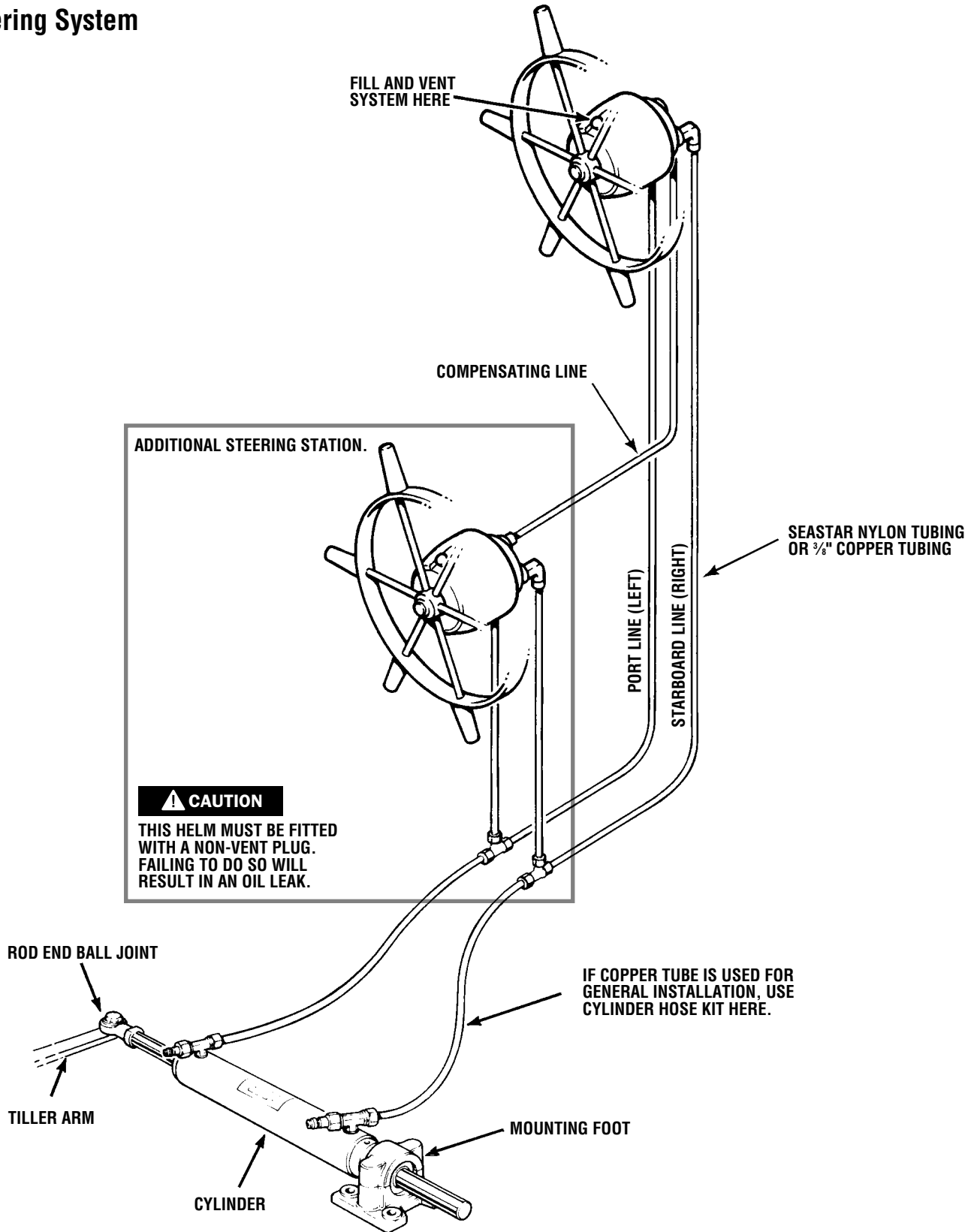

TOOLS

Standard Helm Mounts

You will need the following tools to complete your installation.

- 3" (77mm) diameter Hole Saw or Key Hole Saw and a
- $\frac{5}{16}$ " (8mm) dia. Drill
- $\frac{7}{16}$ ", $\frac{9}{16}$ ", $\frac{5}{8}$ " and $\frac{3}{4}$ " Open End type Wrench/Spanner
- $\frac{15}{16}$ " Socket

Optional Helm Mounts

- Square Bezel Backmount, HA5418, 4 $\frac{1}{2}$ " (115 mm) Hole Saw
- Round Bezel Backmount, HA5417, 4 $\frac{3}{8}$ " (112mm) Hole Saw
- Rearmount Helm, HH5261, 62 $\frac{13}{16}$ " (21mm) Drill
- Tilt Helms 4 $\frac{1}{2}$ " (115mm) Hole Saw

Additional Tools Needed

20° Mount Wedge

- Key Hole or Sabre Saw
- $\frac{5}{16}$ " (8mm) dia. Drill
- $\frac{1}{2}$ " Wrench/Spanner, Box or Open End type
- $\frac{7}{16}$ " Socket and Drive

Cylinder, ATM and TM Models

- $\frac{3}{4}$ " Wrench/Spanner, Box or Open End type, 2 required.

Cylinder, Model 125 - 8EM

- 1 $\frac{5}{16}$ " Wrench/Spanner, Open or Adjustable type.

Cylinder, Other Models

- No special tools required.

CAUTION

Do not remove protective caps from fittings and fitting ports until hose or tube connections are made. Contaminants in the steering system may cause premature wear and steering malfunctions.

NOTICE

Disposing of excess, left over, or used fluid. If the original oil bottle is unavailable, dispose of the steering fluid in an environmentally conscientious manner, adhering to local and federal environmental regulations.

Always wear safety glasses and protective clothing when working around hydraulic fluid and components.

MOUNTING THE HELM

Mount the SeaStar helm to the dash board as required for your model-application. Refer to figures 2,3,4,5 or 6 and use appropriate mounting template.

The helm may be mounted with the helm shaft horizontal, vertical or any angle in between.

The filler plug must always be in the uppermost position.

⚠ CAUTION

Fittings inserted in the rear of the helm should be installed until finger tight and then turned an additional 1–1/2 to 2–1/2 turns depending on desired orientation of fitting. **DO NOT exceed 156 in./lbs (17.6 Nm).**

⚠ CAUTION

If more than one steering station is installed, the fill-vent plug on all but the uppermost helm must be replaced with a non-vent plug which is included in a dual station fitting kit. (See page 14).

Determine desired mounting position. Ensure that the steering wheel will not interfere with other functional equipment. Check for adequate space behind dash for fitting and line connections.

⚠ CAUTION

If a 20° mounting wedge is used, cut out dash as per mounting wedge template and mount helm directly to the 20° wedge.

⚠ WARNING

Use self-locking type fasteners only; substituting non-self locking fasteners can result in loosening or separation of equipment and loss of steering control.

Do NOT exceed 110 in./lbs. (12 Nm) torque on helm and wedge nuts and bolts.

Install elbow fittings supplied with helm to ports marked S and P. Note ports marked R are for the connection of additional helm and auto pilot compensating lines. Straight connectors may be substituted.

Use a pipe sealant such as Loctite P.S.T. or equivalent on all pipe threads. Do not use "tape" sealers.

Mount helm to dashboard or console and lightly **grease taper of helm shaft**. Mount steering wheel to helm.

Tighten steering wheel shaft nut before filling and purging the steering system. Tighten nut to 150 in./lbs. (17 Nm).

Do not exceed 200 in./lbs. (22 Nm).

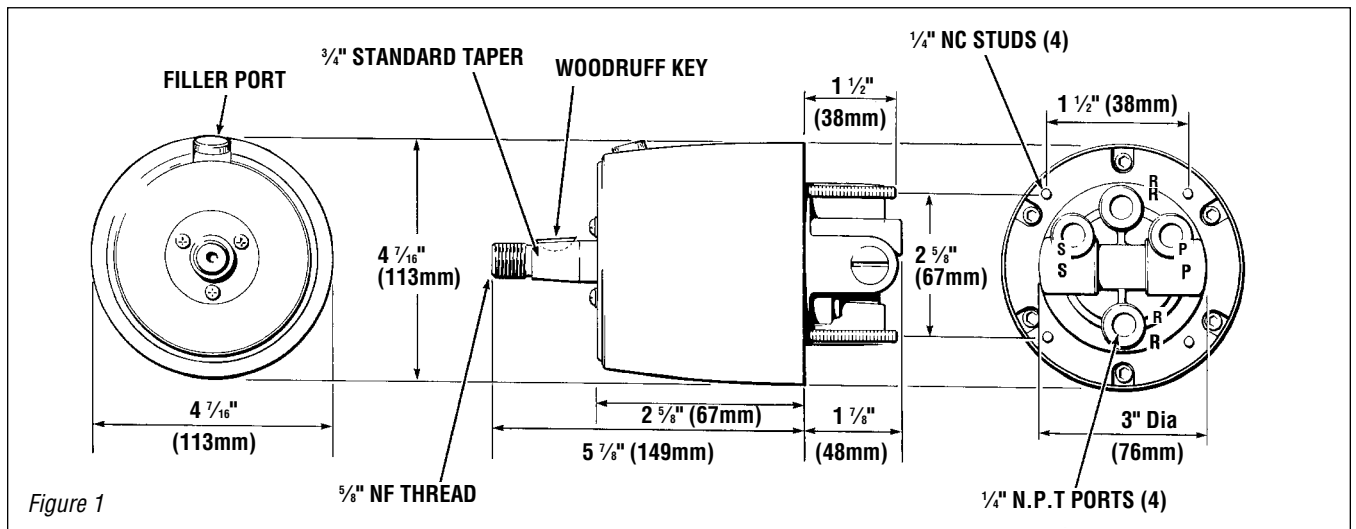
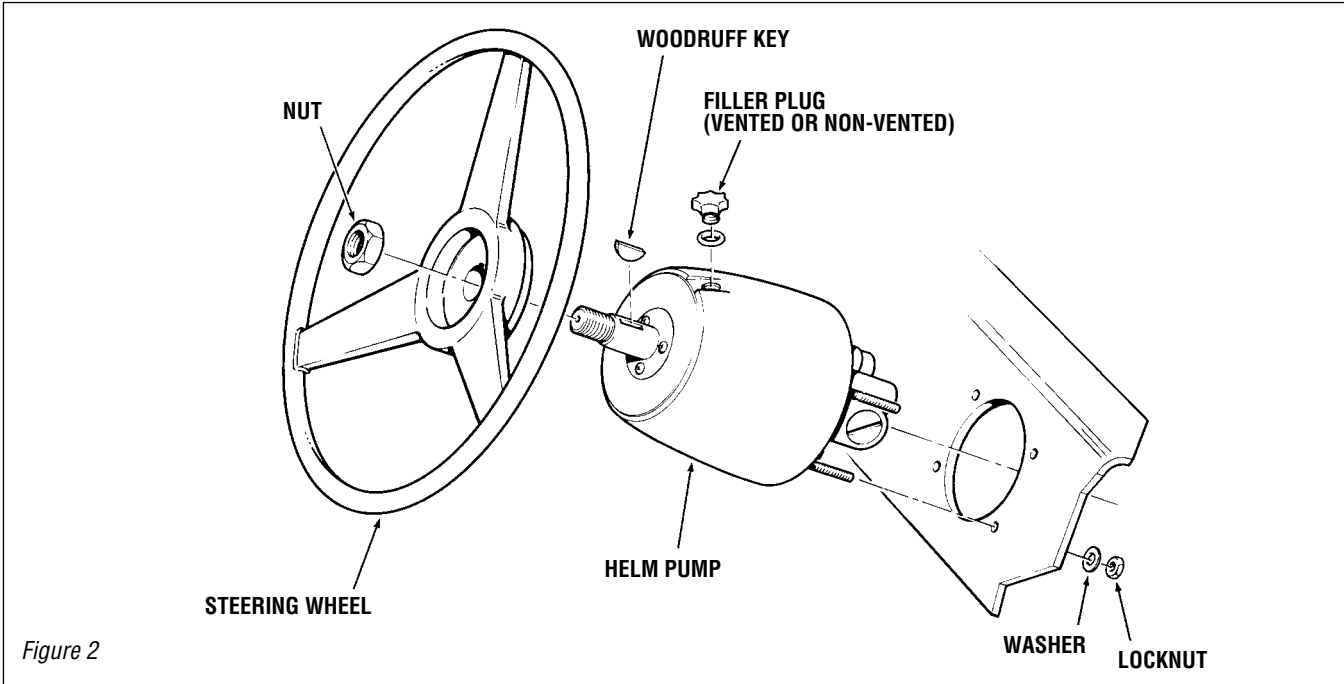
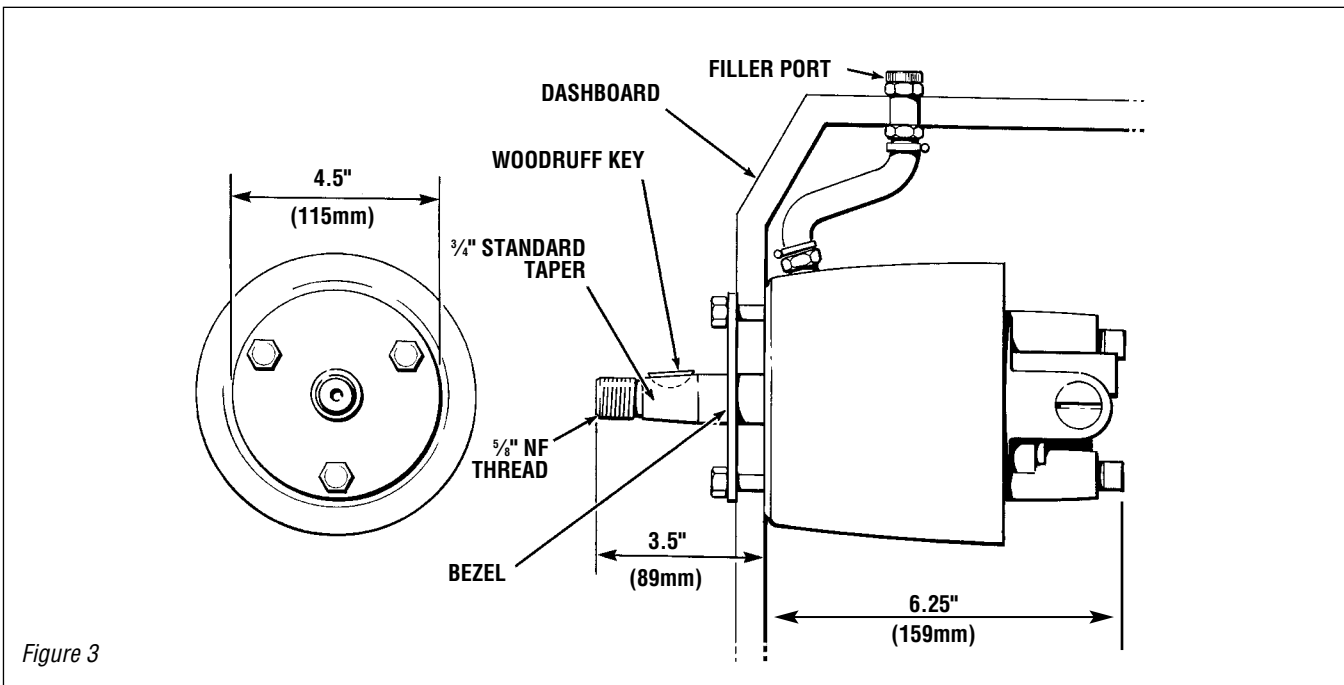

Figure 1

Standard Helm Mounting Configuration



Rear Mount Helm Configuration



Back Mount Kits

- Used to retrofit a new Seastar standard helm in the old 4.5" (115mm) diameter hole.
- or reduce the helm protrusion from the dash by the thickness of the dash.
- or retrofit new Seastar standard helm into hole cutouts for mechanical and hydraulic steering as per chart.

STEERING MANUFACTURER	HELM MODEL TYPE	SYSTEM	BACKPLATE KIT REQ
TELEFLEX	SAFE-T	MECHANICAL	YES
	BIG-T	MECHANICAL	YES
	ROTARY	MECHANICAL	YES
	RACK AND PINION	MECHANICAL	NO
	SYTEN	HYDRAULIC	YES
MORSE	ROTARY	MECHANICAL	NO
	RACK AND PINION	MECHANICAL	NO

Back Mount Kit Square Configuration (part # HA5418)

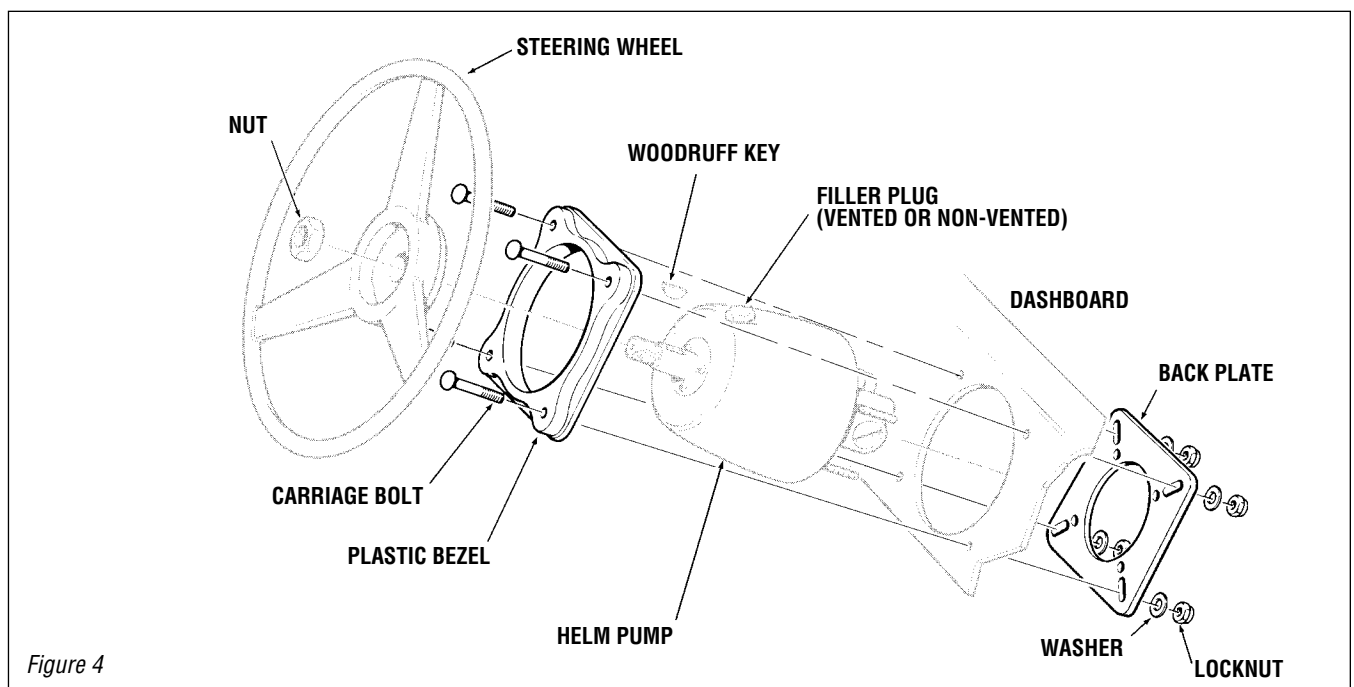

Back Mount Kit Round Configuration (part # HA5417)

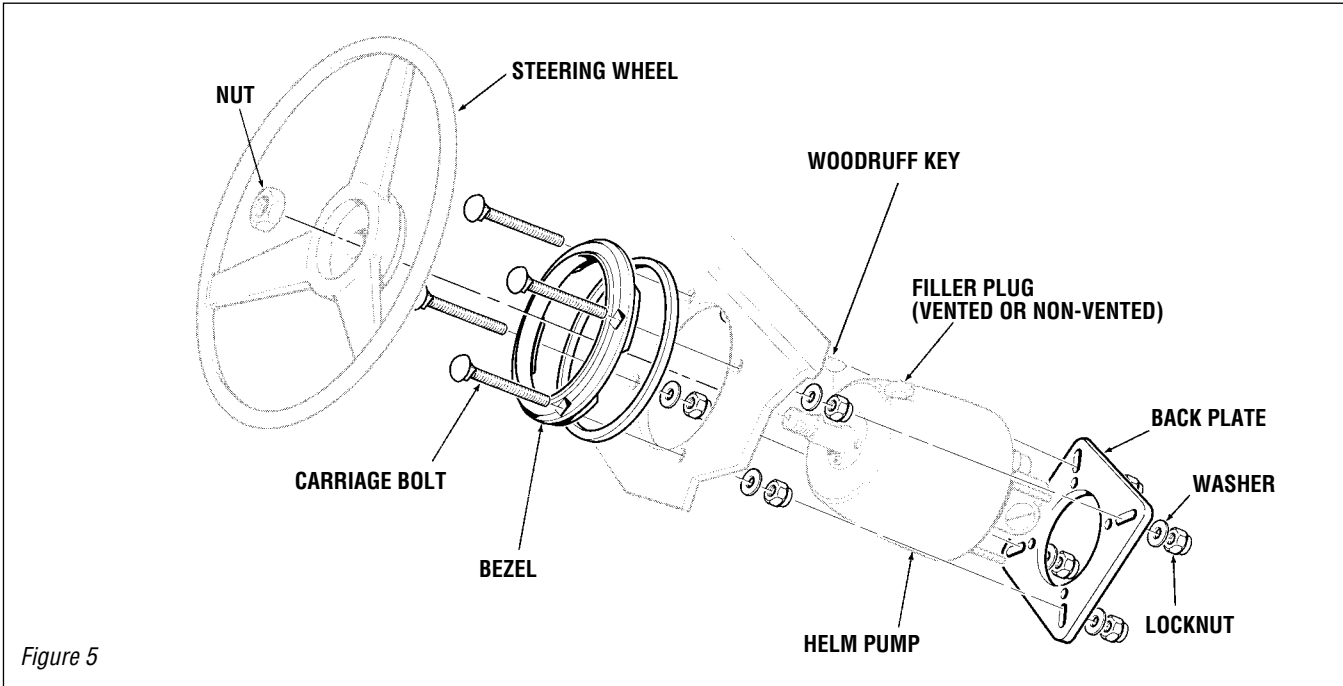

Figure 5

20° Wedge (part # HA5419 & HA5408 c/w Drain kit)

This kit is designed to mount the helm at a 20° angle to the mounting surface. Four possible mounting configurations are available.

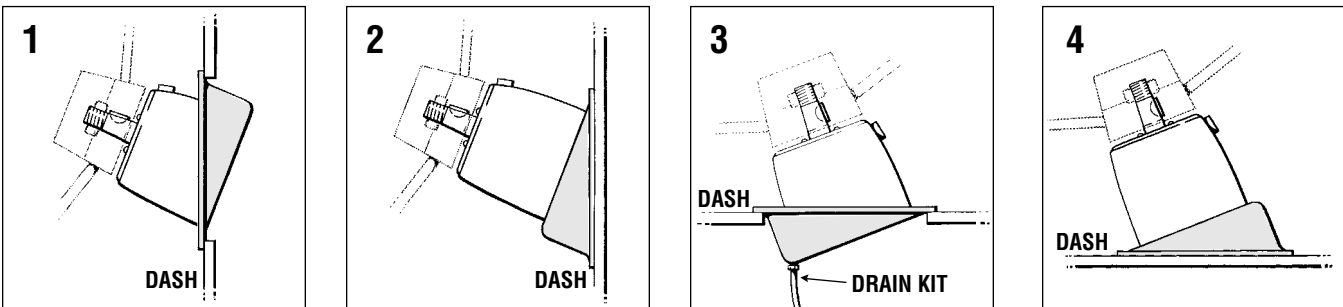

Figure 6

▲ For this configuration use HA5408

NOTICE

Configuration No. 1 and 3 reduces helm protrusion to 3-3/4".
 Configuration No. 3 may result in water being trapped in wedge.
 Use wedge with drain pipe, part No. HA5408.

Tubing Installation

SeaStar I Systems

Use only SeaStar $\frac{3}{8}$ " Nylon Tubing or $\frac{3}{8}$ " Copper Tubing.

SeaStar II Systems

Cylinder Hose Kit, Part No. HF5507 is required for systems installed with Copper Tube.

Use only $\frac{3}{8}$ " Copper Tube or SeaStar I - II Outboard Hose, or equivalent, such as Aeroquip 2651 Hose. Cylinder Hose Kit, Part No. HF5508 is required for systems installed with Copper Tube.

NOTICE

Cylinder Hose Kit, Part No. HF5508 may also be used with SeaStar I Systems. Cylinder Hose Kit Part No. HF5507 should not be used with SeaStar II Systems.

Seastar Nylon Tubing is available in the following lengths:

25 Ft.....	7.6 m.....	Part No. HT5092
50 Ft.....	15.2 m.....	Part No. HT5095
75 Ft.....	22.8 m.....	Part No. HT5097
100 Ft.....	30.4 m.....	Part No. HT5100
1000 Ft.....	303.0 m.....	Part No. HT5101

Fittings

All necessary fittings are supplied with a single steering station system. Fitting Kit, Part No. HF5502 is required for each additional steering station and or auto pilot interface.

Seastar Fittings are Available as Follows:

280327	Tube Nut, for $\frac{3}{8}$ " Nylon and Copper Tube, 1 ea. only
280929	Union Coupling Ftg., Tube to Tube, 1 ea. only
287129	Connector Ftg., Tube to $\frac{1}{4}$ " NPT Male, 1 ea. only
113124	Elbow Ftg., Tube to $\frac{1}{4}$ " NPT Male, 1 ea. only
018023	Tee Ftg., 3 x Tube, 1 ea. only
285020	Tee Ftg., Ends Tube and $\frac{1}{4}$ " NPT Male, Center Tube, 1 ea. only
280524	Connector Ftg., Tube to $\frac{3}{8}$ " NPT Male, 1 ea. only
284826	Tee Ftg., Ends Tube , Center $\frac{1}{4}$ " NPT Female, 1 ea. only
280421	Elbow Ftg., Tube to $\frac{3}{8}$ " NPT Male, 1 ea. only
286624	Elbow Ftg., Tube to $\frac{1}{4}$ " NPT Female, 1 ea. only
718725	Cap Plug Nut

Seastar Helm Seal Kits

DESCRIPTION	PART#
Old Style, HH5201, HH5202, etc.,	HS5151
Old Style Helm Shaft Seal only,	225320
New Style, HH5271, HH5272, etc.,	HS5176
New Style Helm Shaft Seal only,	225226

CYLINDER MOUNTING

General

Proper cylinder installation is the key to the successful operation of the hydraulic steering system. An incorrectly installed cylinder is subject to rapid seal and bearing wear and non-repairable damage.

Minimum side loading of cylinder rod and maximum cylinder performance of ATM and TM Models can be achieved as illustrated below.

An imaginary line drawn through the tiller arm hole at both hard over positions will create the cylinder centre line.

With tiller arm at hard over positions, angle X and Y should be the same.

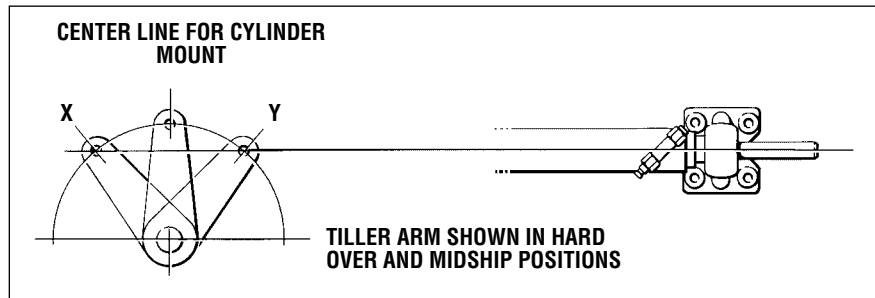

Figure 7

Select the diagram and dimensional data that corresponds with your cylinder model. Note, not all possible cylinder mounting configurations are shown, however, all necessary dimensions are shown regardless of mounting configurations.

⚠ CAUTION

Cylinders should always be secured with thru bolts, not with lag screws. (Where applicable).

Cylinder ports for hose connection should always be in the uppermost position. If this is absolutely not possible, cylinder should be left unmounted until the steering system is filled and purged free of air, while leaving cylinder ports in an uppermost position to assist air removal from the cylinder(s), then mount.

Protect cylinder rods from nicks and scratches, which can cause cylinder to leak, and result in loss of steering.

All parts used are corrosion resistant, however with extended operation under extremely corrosive conditions, corrosion may occur and affected parts should be replaced.

In order to avoid excess steering loads and optimize steering characteristics, outdrive trim tabs must be adjusted in accordance with engine manufacturer's instructions for specific motor/boat combination. Failure to do so can affect boat performance and safety of operation.

**Inboard Aluminum
Cylinders, Models:
BA125-7ATM (HC5312),
BA135-7ATM (HC5313),
BA150-7ATM (HC5314)**

With rudder(s) in the fore and aft position, attach rod end ball joint to the tiller arm or tie bar.

Loosen tube nuts on cylinder fittings. Extend cylinder rod to arrive at 20" (508mm) from center of rod end ball joint hole to the center of the mounting foot, or at a distance of 6 7/16" (164mm) center of rod end ball joint hole to cylinder face as illustrated below.

CAUTION

There is no adjustment for centering cylinder after installation. Correct mounting at this time is very important. Total cylinder rod travel is 7" (178mm).

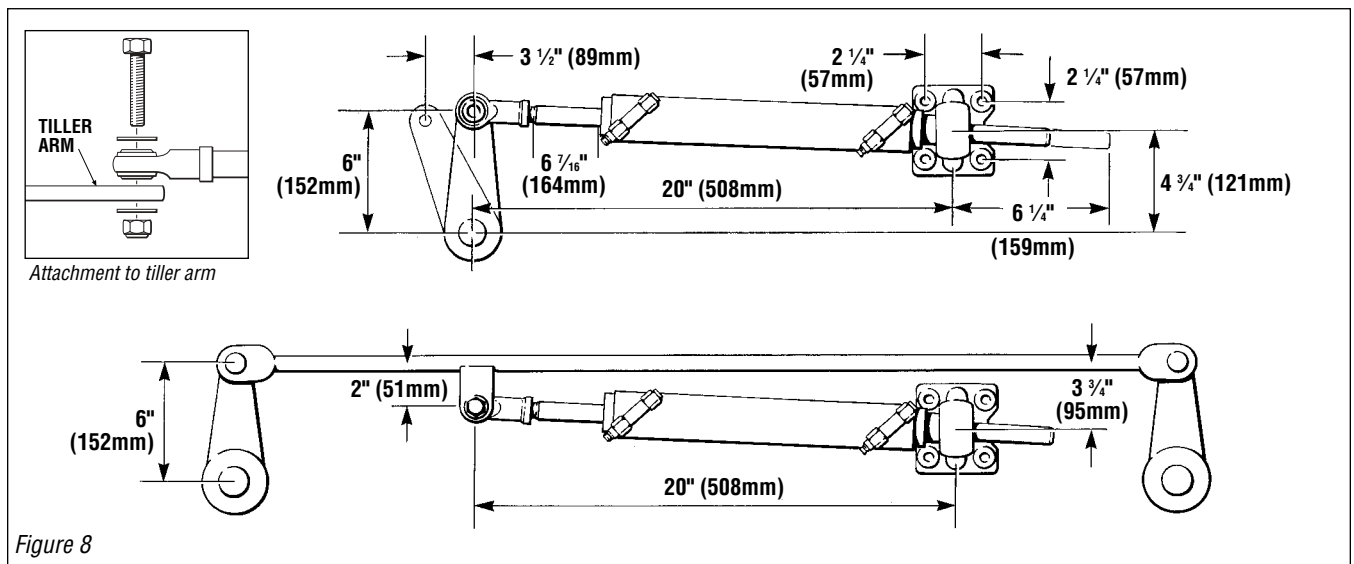

Figure 8

NOTICE

For tie bar systems, cylinder may be mounted directly to the tie bar as shown, or to one of the two tiller arms, as long as dimensional data is adhered to.

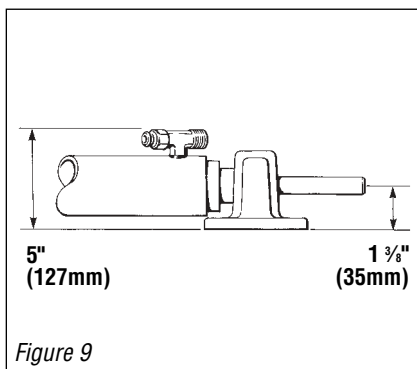

Figure 9

Secure mounting foot to transom or mounting bracket, using four 5/16" (8mm) Grade 5 bolts (corrosion resistant) and self-locking nuts.

In order to obtain a correct push and pull angle between the tiller arm and cylinder, or tie bar and cylinder, the cylinder should be parallel to transom, or tie bar, or the keel line, depending on mounting configuration, when cylinder rod is fully extended (out) or fully retracted (in).

Swing rudder(s) back and forth at this time, to ensure free movement of cylinder. Ensure that there is no binding of ball joint.

CYLINDER MOUNTING

INBOARD (TM)

Inboard Cylinders, Models:

BA 150-7TM (HC5318, HC5318-A)

BA 150-9TM (*HC5369/HY/HYC)

BA 175-7TM (HC5319)

BA 175-9TM (*HC5373/HY/HYC)

* Fittings are NOT supplied with HC5369HY, HC5369HYC, HC5373HY or HC5373HYC and must be purchased separately.

With rudder(s) in the fore and aft position, attach rod end ball joint to the tiller arm or tie bar.

Extend the cylinder rod to arrive at 21" (533mm) from center or rod end ball joint to the center of the mounting foot as illustrated below.

Position the mounting foot in accordance to dimensional figures (below) and secure to mounting bracket or surface using four 3/8" (10mm) Grade 5 bolts and self-locking nuts.

In order to obtain a correct push and pull angle between tiller arm and cylinder, or tie bar and cylinder, the cylinder should be parallel to transom, or tie bar, or the keel line, depending on mounting configuration, when cylinder rod is fully extended (out) or fully retracted (in).

Swing rudder(s) back and forth at this time, to ensure free movement of cylinder. Ensure that there is no binding of ball joint.

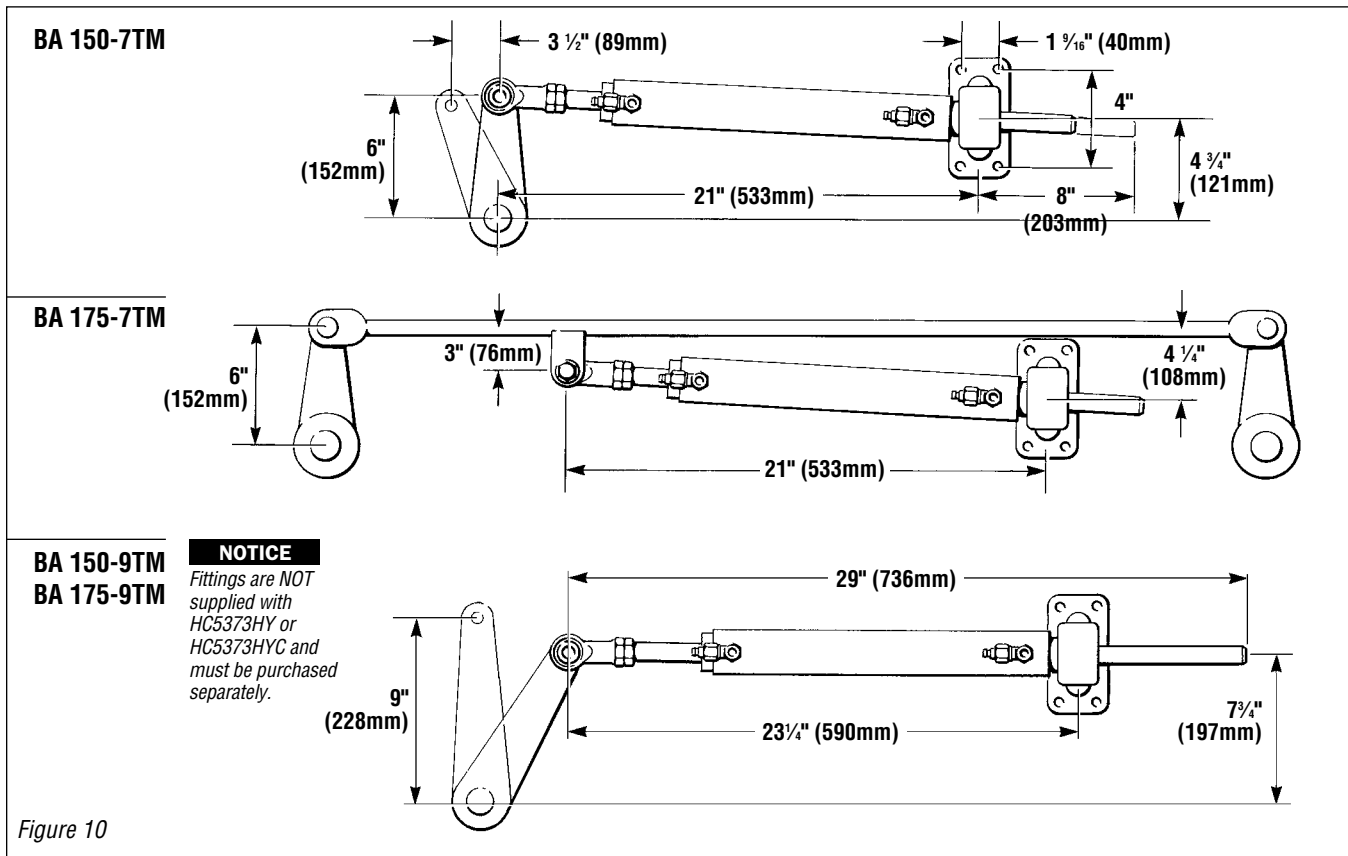

NOTICE

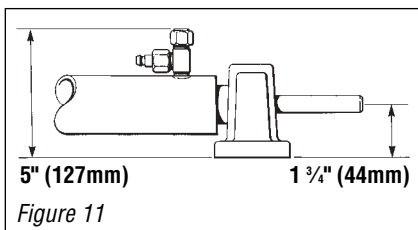

For tie bar systems, cylinder may be mounted directly to the tie bar as shown, or to one of the two tiller arms, as long as dimensional data is adhered to.

**Engine Mounted Cylinder
Models: BA 125-8EM,
BA 135-8EM, BA 125-8EMV**

A support tube provided by the engine manufacturer, must be used for these two cylinder models. These cylinders are mounted to the sterndrive's support or guide tube in the same manner as a steering cable.

Thoroughly lubricate support tube and cylinder rod with a high quality anti-corrosive type marine grease such as OMC Triple Guard or equivalent, before mounting cylinder to support tube.

Slide well greased cylinder rod into and through well greased support tube and thread cylinder fully onto support tube as shown below.

125-8EM (HC5328)

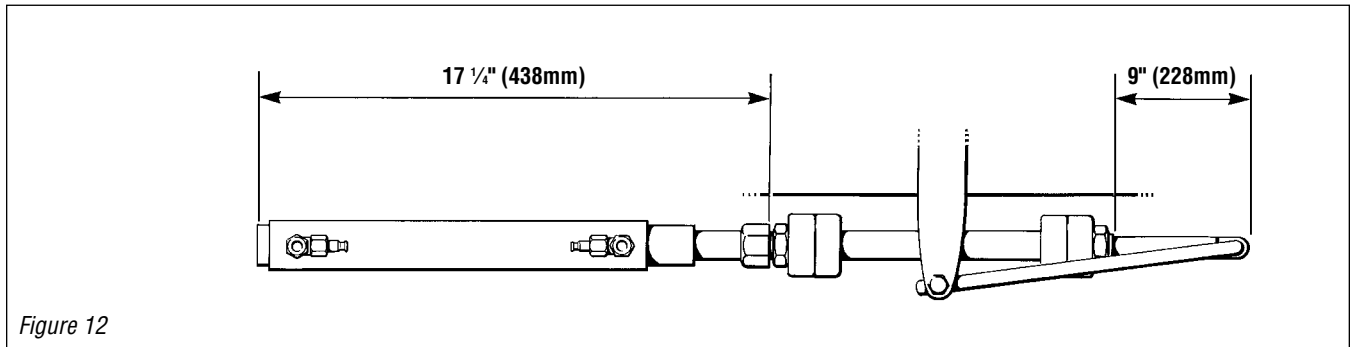

Figure 12

BA 135-8EM (HC5327)

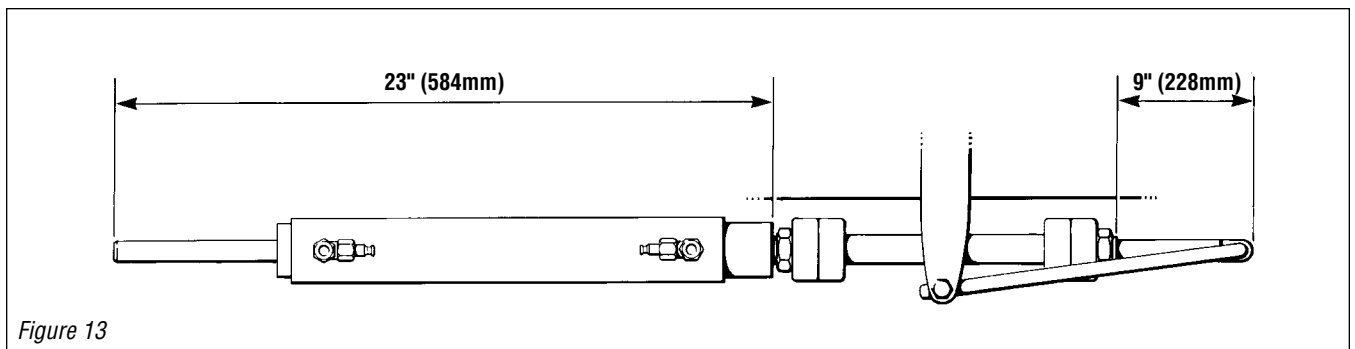

Figure 13

BA 125-8EMV (HC5330)

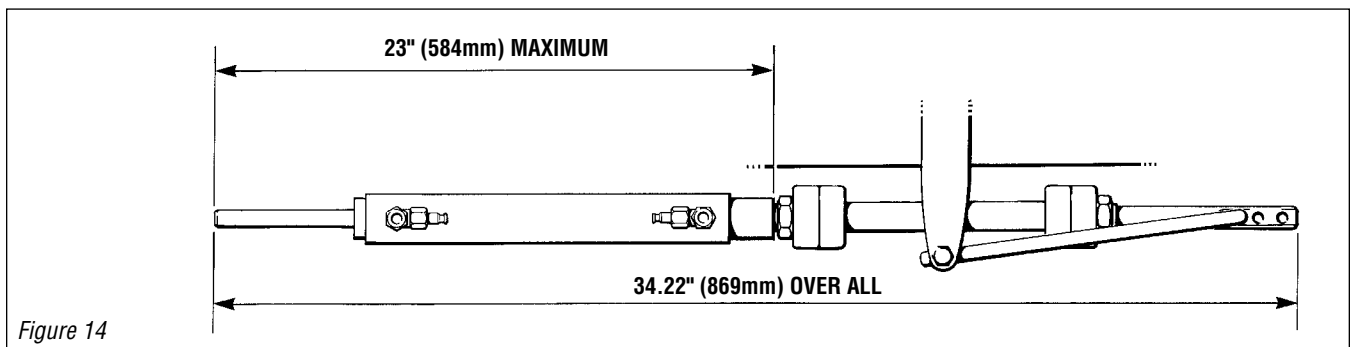

Figure 14

CYLINDER MOUNTING

STERNDRIVE

Model: BA 150-7EM (HC5326)

This cylinder is designed for use with 1984 to date Mercruiser, and OMC Cobra non power assisted steering sterndrives (OMC Cobra requires Teleflex part HA5424). Sterndrives equipped with optional power assist steering require Cylinder Model 125-8EM.

NOTICE

Quicksilver Clevis Adapter Kit, part No. B98735A1 is required to complete cylinder connection to Mercruiser sterndrives. This part is supplied with the Quicksilver Tie Bar Kit for twin sterndrives.

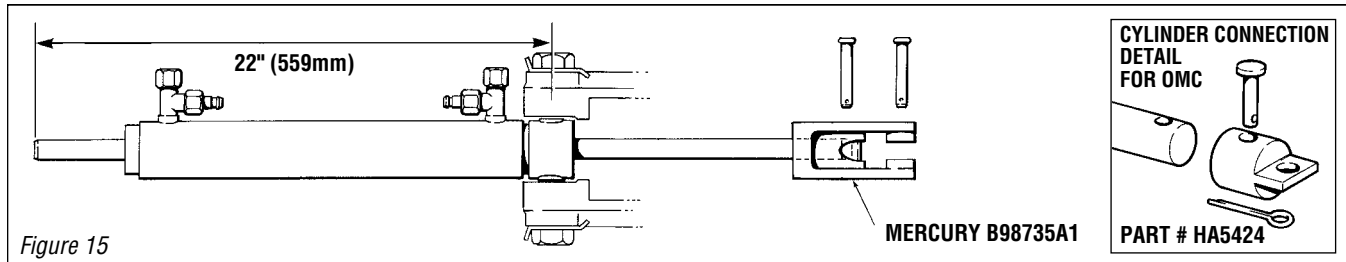

⚠ CAUTION

When connecting the cylinder to a Mercruiser the two washer spacers must be installed between the cylinder and mounting bracket.

When connecting the cylinder to an OMC Cobra, the two bushings must be inserted to the cylinder mounting holes.

Model: 92-VPS (HC5331)

This cylinder is designed for use with 1992 to date Volvo Power Sterndrive.

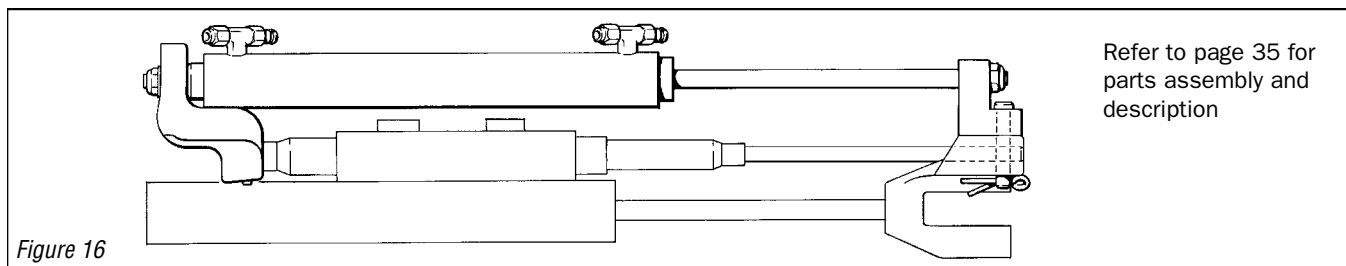

Model: BA135-7EM (HC5332)

This steering cylinder has been designed to be used with Mercruiser Non-power assisted Alpha 1 and Bravo 1, 2 & 3 Stern Drives.

⚠ CAUTION

Do not use extruded nylon tubing for an HC5332 stern drive cylinder installation. Teleflex Canada recommends the use of outboard hydraulic hose kits.

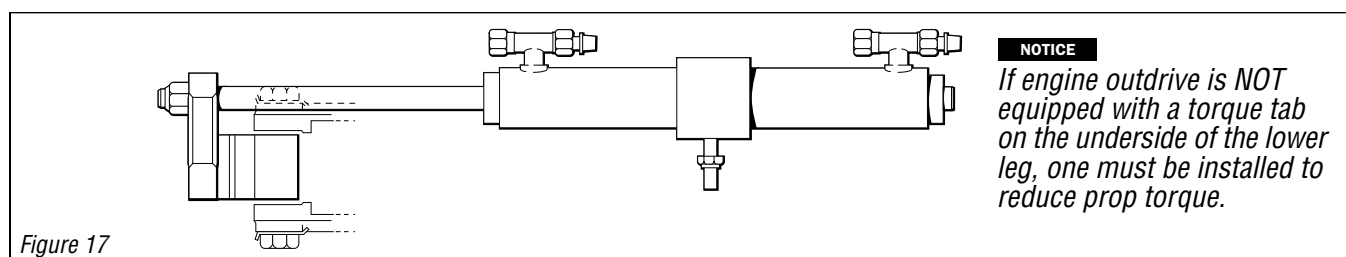

TUBING INSTALLATION

General

WARNING

Do not allow nylon tubing to contact, or come too close to hot engine. Extreme heat will lower burst pressure or melt nylon tubing. In either case instant loss of steering may occur.

The following recommendations refer to $\frac{3}{8}$ " soft copper tubing and Seastar $\frac{3}{8}$ " nylon tubing.

Route the tubing so that it will not interfere with hatchways or other types of functional equipment.

Do not allow tubing to kink or collapse while routing through vessel. Any piece of tubing that has collapsed, must be replaced or spliced with a union coupling fitting.

Tie down tubing at regular intervals, using non-metallic type ties.

Do not allow the tubing to rest or chafe against a sharp or abrasive surface.

CAUTION

Teleflex can not be responsible for any consequences resulting from the use of a substitute tube or hose.

Autopilot

An autopilot designed for use with hydraulic steering may be teed into your Seastar steering system at any convenient point in the system.

Installing shut-off valves in hydraulic lines running from autopilot pump set to steering system lines will simplify trouble shooting and servicing at a later time if necessary.

Autopilot selection must be compatible with oil used in your SeaStar steering system. (See page 15)

Seastar Helm Pumps are equipped with internal check valves allowing interface with Autopilots without the need for addition check valves.

System Connection

WARNING

Never attach copper tubing or any rigid tube or pipe directly to cylinder(s).

Cylinders articulate during the hard over to hard over movement and require a flexible hose to compensate for the articulation.

This section covers the tube nut and tube connections ($\frac{3}{8}$ " copper and $\frac{3}{8}$ " nylon) to helm(s) and cylinder.

Refer to system diagram for general system connection and for identification of components.

Tube nuts supplied with components and fitting kits are suitable for use with $\frac{3}{8}$ " OD copper tube and Seastar $\frac{3}{8}$ " OD nylon tubing.

A quality Teflon base thread sealer should be used on all pipe threads, such as Loctite P.S.T. or equivalent. Failing to use a thread sealant could result in leaks.

Do not use pipe sealant on tube nut portion of fitting.

Screw elbow fittings into helm ports marked S and P.

Ensure that elbow fittings are finally oriented in desired position, for connection to tubing.

In a multi-steering station system a compensating line must run from helm port R to helm port R. The compensating line must always be connected from the bottom R port on the highest helm, to the top R port on the lowest helm.

Dual Station

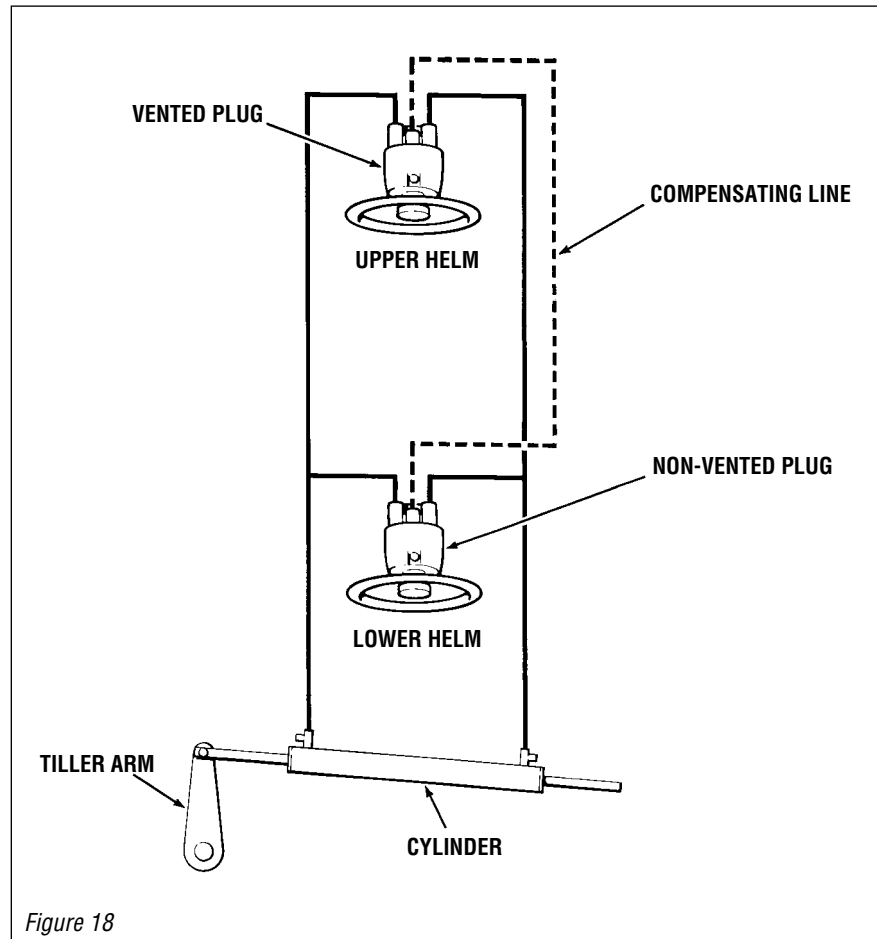

Figure 18

An autopilot compensating line may be teed into an existing compensating line between two helms or directly into a bottom R port on the Seastar helm. Connector fittings for compensating line are supplied with fitting kit HF5502.

Fitting kit, part no. HF5502 is required for additional steering helm(s) or for an autopilot connection.

CAUTION

Fitting kit, part no. HF5502 also contains a solid non-vent plug, which must be used on all helms other than the highest helm in a steering system.

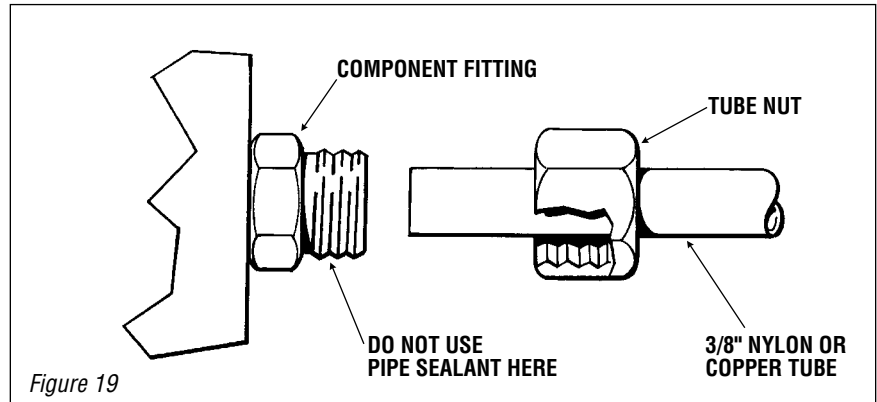

Slide tube nut over tubing.

Push tubing into bottom of component fittings.

Hand tighten tube nut, ensuring that tube is bottomed against fitting, while tightening tube nut.

After hand tightening tube nut, tighten nut an additional one and a half turns with a $\frac{5}{8}$ " wrench.

Hydraulic Fluid

Acceptable and recommended oils for your steering system are:

Seastar Hydraulic Fluid, part no. HA5430
 Texaco H015
 Aero Shell Fluid #41
 Esso Univis N15 or J13

Chevron Aviation Fluid A
 Mobil Aero HFA
 Fluids meeting Mil H5606C specifications.

CAUTION

Never use brake fluid. Any non-approved fluid may cause irreparable damage, loss of steering, and cancellation of warranty.

Automatic transmission fluid Dexron II may be used in an emergency. In cases of extreme emergency any non-toxic, non-flammable fluid may provide temporary steering.

Seastar hydraulic oil is not available from your local gas station. Order a spare bottle from your Teleflex/Seastar dealer.

Vent Plug
 (part #HA5431)

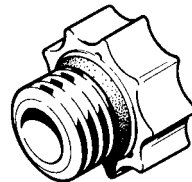

Figure 20



- Must be used with helm pump on all single steering station systems.
- Must be used on upper-most helm pump only on multi-steering station systems.
- Vent hole: actual size as shown.
- Colour: threads, silver – cap, black

Non-Vent Plug
 (part #HA5432)

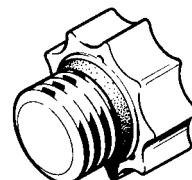

Figure 21



- Must be used on all helm pumps other than upper-most helm pump on multi-steering station systems.
- This non-vent plug is supplied with additional station fitting kit no. HF5501 and HF5502.
- Actual size shown.
- Colour: black (previously silver)

FILLING AND PURGING THE SYSTEM

Read First

These instructions show how to fill and purge a Single Station Cylinder System. For twin station and/or twin cylinder filling and purging instructions read instructions on pages 18 and 19 first and then proceed with instructions on page 17.

NOTICE

This procedure requires two people. One person may not be able to remove all the air from the system which will result in spongy, unresponsive steering.

During the entire filling procedure, oil **must** be visible in the filler tube. **Do not** allow the oil level to disappear into the helm pump, as this may introduce air into the system and increase your filling time.

Hydraulic Oil Requirements

2 bottles (2 quarts or litres) for single station and single cylinder systems.

1 additional bottle for each additional helm, cylinder, or auto pilot.

NOTICE

These instructions will result in hydraulic oil flushed in and out of the system. Oil can be re-used if filtered through a fine mesh screen such as used for gasoline. If unable to filter oil, an additional bottle of oil is required.

NOTICE

“Bleeder” refers to cylinders fitted with bleed tee fittings. If fitted with bleed tee fitting, open bleeder by unscrewing bleed nipple nut two turns.

If cylinder is not fitted with bleed tee fittings, disconnect hydraulic line from the cylinder fitting. Loosening the hose or tube fitting only, may not cause sufficient oil flow to purge the system.

⚠ CAUTION

Unbalanced Cylinders

The oil level in the helm must be set with the cylinder rod fully retracted. Failing to observe this caution will result in an oil spill at the helm.

Turning the wheel port (left) will retract the cylinder rod.

NOTICE

General

Filling the helm full of oil can be done faster if oil is poured into the helm prior to connecting filler tube and oil bottle to the helm.

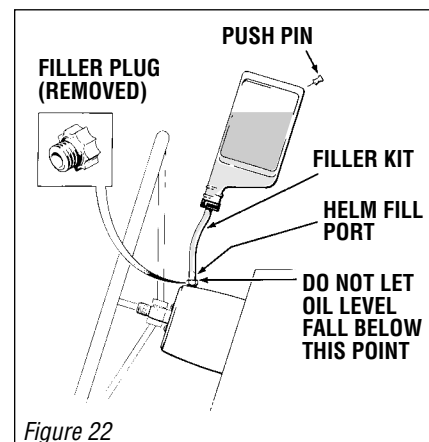

Figure 22

Single Station One Cylinder

HYDRAULIC STEERING

FILLING AND PURGING

Step 1

- Screw the threaded end of the filler tube into the helm filler hole.
- Remove the cap from the oil bottle and holding upright, screw into the filler tube bottle cap. Poke hole in the bottom of the bottle.
- Fill the helm pump full of oil (Oil should always be visible in the filler tube). Use the next bottle at any time throughout the procedure when the oil level drops in the filler tube. Do not proceed with step two until helm is full of oil.

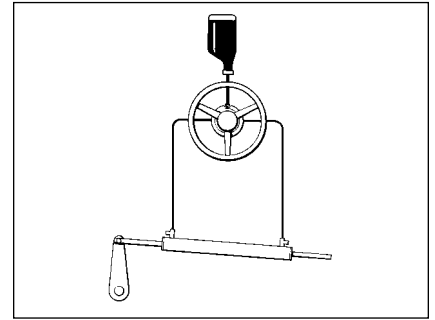

Step 2

- Turn the steering wheel clockwise until the cylinder rod is fully extended on the left side of the cylinder.
- Open left side bleeder.

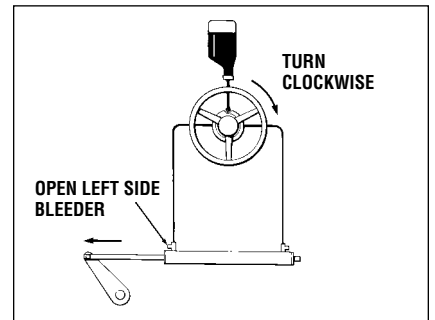

Step 3

- Holding the cylinder rod (to prevent it from moving back into the cylinder) turn the steering wheel counter-clockwise until a steady stream of air free oil comes out of the bleeder. (Drain out approx. 1/2 bottle of oil or as required.)
- While continuing to turn the wheel, close the left side bleeder and let go of the cylinder rod.

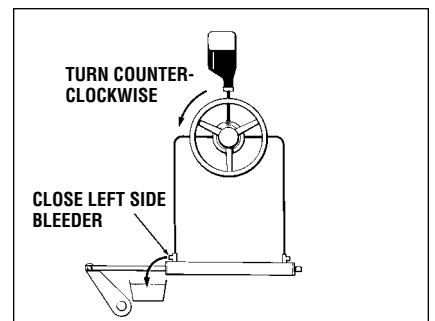

Step 4

- Continue turning the steering wheel counter-clockwise until the cylinder rod is fully extended to the right. (Steering wheel will come to a stop)
- Open the right bleeder.

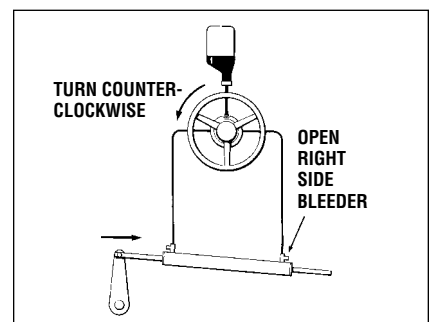

Step 5

- Holding the cylinder rod (to prevent it from moving back into the cylinder) turn the steering wheel clockwise until a steady stream of air free oil comes out of bleeder.
- While continuing to turn the wheel, close the right side bleeder and let go of the cylinder rod.

Fill and purge is now complete

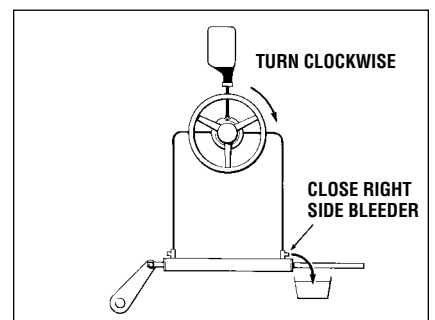

HYDRAULIC STEERING

FILLING AND PURGING

Oil Level Set

- Proper oil level set can be obtained by opening right bleeder and turning steering wheel to the right until fluid level reaches top of plastic filler fitting and then turning wheel one more full turn.

CAUTION

For unbalanced cylinders the oil level in the helm must be set with the cylinder rod fully retracted. Failing to observe this caution will result in an oil spill at the helm.

Turning the wheel port (left) will retract the cylinder rod.

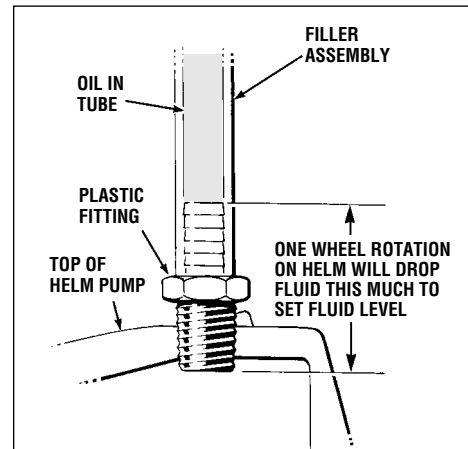

Twin Station Single Cylinder

Perform steps 1 through 5 at station no.1. Then repeat steps 1 - 5 at station no.2. Oil requirements 4 - 5 bottles.

NOTICE

Refer to Oil Level and System Check on page 19.

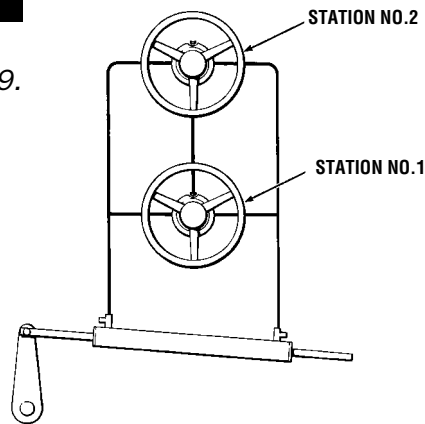

Single Station Twin Cylinder

When performing steps 1 through 5, perform instructions in each step first on cylinder no.1 and then on cylinder no.2, before proceeding to the next step. ie: Perform instructions referring to right side of cylinder first on cylinder no.1 and then on cylinder no.2. Oil requirements 4 - 5 bottles.

NOTICE

Refer to Oil Level and System Check on page 19.

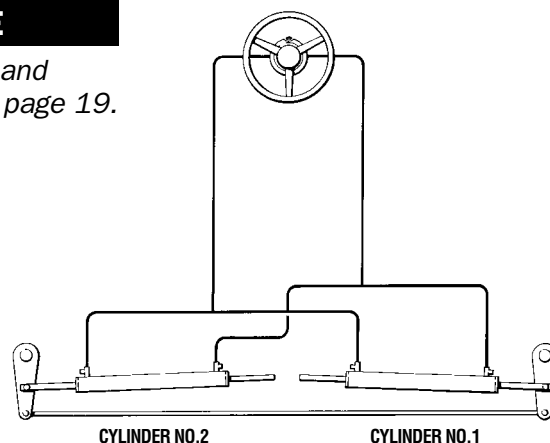

Twin Station Twin Cylinder

Follow same procedure as instructed for single-station / twin-cylinders, beginning at station no.1, and repeat entire procedure at station no.2.

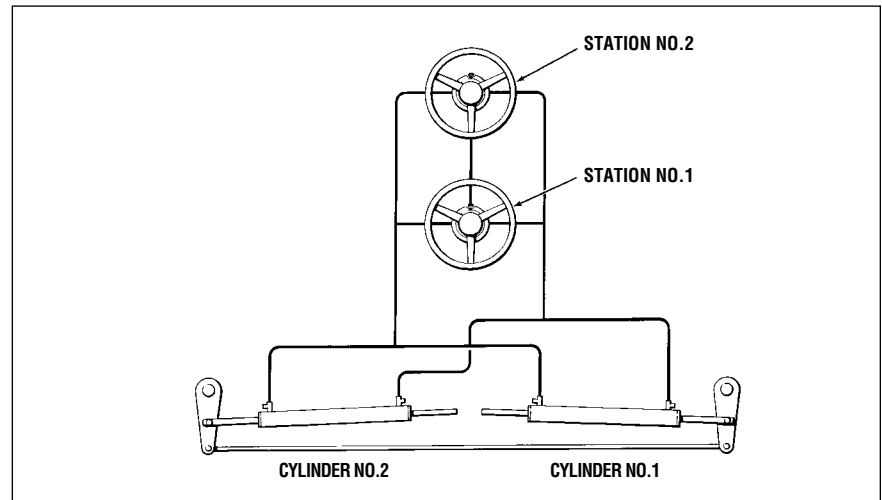

Oil level & System Check

Helm mounted with wheel shaft completely horizontal must be filled to bottom of filler hole at all times. Do not allow oil level to drop more than $\frac{1}{4}$ " (6.3mm)

Helms mounted on a 20° angle or with wheel shaft vertical, oil level should be within $\frac{1}{2}$ " (12.7mm) of hole. Check oil level periodically.

At this time the steering system should be checked for proper connections of hose, tube and fittings, possible leaks, and air removal. To do so, turn steering wheel (any one on a multi-steering station) and pressurize very hard to port. Apply enough force to the wheel to exceed pressure relief valve pressure. You will not harm the helm of the system. While pressure is maintained on the steering wheel, check all port (left) fittings and line connections. Repeat procedure by turning wheel to starboard. Watch the oil level in the helm pump when pressurizing the steering wheel in either hard over positions. If there is no obvious drop in oil level, air has been removed. If there is an obvious drop in oil level, you are compressing air and further filling and purging is required. Repeat Steps 1 thru 5.

If no leaks are obvious, your steering system is ready for use.

WARNING

If leaks are found, correct before using. Failure to correct a leak can lower oil level in system and result in loss of steering.

MAINTENANCE

Maintenance requirements will vary with usage and climate.

Inspection by a qualified marine mechanic is required:

- A** A minimum of two times a year.
- B** At the first sign or indication that the steering system is not operating normally or correctly.
- 1** Check the oil level in the helm pump. This should always be within 1/2" of the bottom of the filler hole.

NOTICE

The special hydraulic oil is not available from your local gas station. Order a spare bottle (HA5430) from your Teleflex/Seastar dealer.

- 2** Check mechanical linkages and connections. Tighten loose parts and replace badly worn parts.
- 3** Check for leaks. See page 19 for how to check for leaks.
- 4** Check hoses for chafing/rubbing marks, and replace if required.
- 5** Sterndrives utilizing a support tube should have the support rod removed, cleaned and greased with an approved marine quality grease bi-annually.
- 6** Check cylinder shaft for nicks and scratches. A damaged cylinder shaft can cause seal failure and leaks. Replacing seals to a damaged cylinder shaft will not stop leaks. A damaged cylinder shaft must be replaced immediately.

WARNING

Failure to comply with maintenance checks may result in loss of steering, causing property damage and/or personal injury.

TROUBLE SHOOTING GUIDE

Seastar hydraulic steering will provide years of safe reliable performance with a minimum of service if properly installed with correct cylinder.

Seastar steering systems have been designed with protection against over-pressure situations, by a pressure relief valve, to minimize the possibility of total loss of steering.

Most faults occur when the installation instructions are not followed and usually show up immediately upon filling the system. Provided below, are the most common faults encountered and their likely cause and solution. The term "Rudder" also applies to stern drives, when applicable.

Sometimes when returning the wheel from a hardover position, a slight resistance may be felt and a clicking noise may be heard. This should not be mistaken as a fault, as it is a completely normal situation caused by the releasing of the lockspool in the system.

WARNING

Whenever in the following text, a solution calls for removal from vessel and/or dismantling of steering system components, such work must only be carried out by a qualified marine hydraulic mechanic. Teleflex offers the following as a guide only and is not responsible for any consequences resulting from incorrect dismantling repairs.

FAULT	CAUSE	SOLUTION
<p>1. During Filling, the helm becomes completely jammed.</p>	<ul style="list-style-type: none"> • Blockage in the line between the helm(s) and the cylinder(s). 	<ul style="list-style-type: none"> • Make certain that tubing has not collapsed during installation. If so, the collapsed section must be removed and re-fitted with a new piece with the aid of tube connectors. Check fittings for incomplete holes. Fittings with incomplete holes, however, are not common.
<p>2. System is very difficult to fill. Air keeps burping out top of helm even after system appears full.</p>	<ul style="list-style-type: none"> • Cylinder(s) has been mounted upside down. This causes air to be trapped in the cylinder(s). • Air in system. 	<ul style="list-style-type: none"> • Mount cylinder(s) correctly, according to cylinder installation instruction. Ports should always be kept in uppermost position. • Review filling instructions.
<p>3. Steering is stiff and hard to turn, even when the vessel is not moving.</p>	<ul style="list-style-type: none"> • Rudder post glands are too tight or rudder post is bent, causing mechanical binding. The same applies to tiller arm and linkage on outdrives. • Restrictions in hose, copper tubing, piping or fittings. • Air in oil. • Wrong oil has been used to fill steering system, like A.T.F. (automatic transmission fluid, or any other oil with a high viscosity factor). • Support tube corroded or seized restricting movement of hydraulic cylinder. 	<ul style="list-style-type: none"> • To test, disconnect cylinder(s) from the tiller arm and turn the steering wheel. If it turns easily, correct above-mentioned problems. Please note that excessively loose connections to tiller arm or tie-bar can also cause mechanical binding. • Find restriction and correct. Note: Collapsing of copper tubing during bending is enough to cause restrictions. • See filling instructions supplied with helm units. • Drain system and fill with recommended oils. • Remove cylinder, clean and re-grease.
<p>4. One helm unit in system is very bumpy and requires too many turns from hardover to hardover.</p>	<ul style="list-style-type: none"> • Dirt in inlet check of helm pump. 	<ul style="list-style-type: none"> • Dismantle helm pump and remove contaminant from make-up checks.

HYDRAULIC STEERING

TROUBLE SHOOTING

FAULT

CAUSE

SOLUTION

5. Steering is easy to turn at the dock, but becomes hard to turn when vessel is underway.

- Steering wheel is too small.
- cylinder(s) too small.
- incorrect setting of trim tab(s) on stern drive.
- incorrectly designed or adjusted rudders, causing binding on rudder post and/or tie bar at cruising speeds.

- fit larger wheel if possible, see installation instructions. If the problem cannot be rectified by the above mentioned solution, proceed with next cause and solution or consult factory.
- replace with larger cylinder(s).
- adjust tab(s).
- seek professional help. Have competent, qualified marine mechanic correct problem.

6. Rudder drifts to port or starboard while vessel is underway, even when wheel is not being turned.

- Dirt in check valves.

- Remove check valve plugs. These are the larger plugs on either side on rear of helm. Clean ball seats and balls and re-assemble.
Note: Be prepared to lose a certain amount of oil during this procedure. Have a small can available. Refill system when check balls have been re-assembled.

7. Turning one wheel causes second steering wheel to rotate.

- See fault No. 6.

- See fault No. 6.

8. Seals will sometimes leak if steering system is not vented at uppermost helm.

- The Seastar helm has a field replaceable wheel shaft seal which can readily be replaced by removing the steering wheel and seal cover held in place by three small screws. Quad ring no. 210 is found in Seastar helm seal kit HS5151.

NOTE: Seal kits are available for Seastar cylinders, however, these must only be used by a qualified marine mechanic.

TECHNICAL INFORMATION

Bolt Torque Specifications

Values are stated in: **in/lbs (N.m)**

Bolt Size	18-8SS	Brass
2-56	2.5 (.282)	2.0 (.226)
2-64	3.0 (.338)	2.5 (.282)
3-48	3.9 (.440)	3.2 (.361)
3-56	4.4 (.497)	3.6 (.407)
4-40	5.2 (.587)	4.3 (.486)
4-48	6.6 (.740)	5.4 (.610)
5-40	7.7 (.869)	6.3 (.712)
5-44	9.4 (1.06)	7.7 (.869)

These are the recommended maximum torque values for reusable dry bolts. Bolts should be torqued to this value +0% -20%. For lubricated bolts, multiply the dry bolt torque values by .75.

Bolt Size	18-8SS	Brass
6-32	9.6 (1.08)	4.9 (.554)
6-40	12.0 (1.35)	9.9 (1.12)
8-32	20.0 (2.25)	16.0 (1.81)
8-36	22.0 (2.48)	18.0 (2.03)
10-24	23.0 (2.59)	19.0 (2.14)
10-32	32.0 (3.61)	26.0 (2.94)
1/4"-20	75.0 (8.47)	62.0 (7.01)
1/4"-28	94.0 (10.6)	77.0 (8.70)

Bolt Size	18-8SS	Brass
5/16"-18	132.0 (14.91)	107.0 (12.10)
5/16"-24	142.0 (16.04)	116.0 (13.11)
3/8"-16	236.0 (26.66)	192.0 (21.71)
3/8"-24	259.0 (29.20)	212.0 (23.97)

Values are stated in: **ft/lbs (N.m)**

Bolt Size	18-8SS	Brass
7/16"-14	31.0 (42.00)	26.0 (35.25)
7/16"-20	33.0 (44.74)	27.0 (36.61)
1/2"-13	43.0 (58.30)	35.0 (47.45)
1/2"-20	45.0 (61.01)	37.0 (50.17)
9/16"-12	57.0 (77.28)	47.0 (63.72)
9/16"-18	63.0 (85.42)	51.0 (69.15)

Bolt Size	18-8SS	Brass
5/8"-11	93.0 (126.09)	76.0 (103.04)
5/8"-18	104.0 (141.00)	85.0 (115.24)
3/4"-10	128.0 (173.55)	104.0 (141.00)
3/4"-16	124.0 (168.12)	102.0 (138.29)
7/8"-9	194.0 (236.03)	159.0 (215.58)
7/8"-14	193.0 (261.67)	158.0 (214.22)

Bolt Size	18-8SS	Brass
1"-8	287.0 (389.12)	235.0 (318.62)
1"-14	259.0 (351.16)	212.0 (287.43)

NOTICE Torque values for 18-8 stainless steel and brass bolts are taken from a torque guide by ITT Harper. All results correspond well with basic bolt equations, using a bolt factor of 0.2 and a factor of 3/4 for a reusable connection.

Helm Pump

	SEASTAR I	SEASTAR II
DISPLACEMENT	1.7 cu. in. – (27.8 cc)	2.4 cu. in. – (39.3 cc)
RELIEF VALVE	1000 PSI – (70 Bar)	1000 PSI – (70 Bar)
PORTS	1/4" NPT	1/4" NPT

Helm Pump Shaft

SEASTAR I	SEASTAR II
3/4" Standard Taper	3/4" Standard Taper
1" Per Ft. 5/8" NF Threads	1" Per Ft. 5/8" NF Threads
3/16" Key	3/16" Key

Cylinder

HC5312	BA125-7ATM, inboard type
HC5313	BA135-7ATM, inboard type
HC5314	BA150-7ATM, inboard type
HC5318	BA150-7TM, inboard type
HC5318-A	BA150-7TM, inboard type
HC5319	BA175-7TM, inboard type
HC5369	BA150-9TM, inboard type
HC5369HY	BA150-9TM, inboard type
HC5369HYC	BA150-9TM, inboard type
HC5373	BA175-9TM, inboard type
HC5373HY	BA175-9TM, inboard type
HC5373HYC	BA175-9TM, inboard type
HC5326	BA150-7EM, sterndrive type
HC5327	BA135-8EMV, sterndrive type
HC5328	125-8EMV, sterndrive type
HC5329	125-8VPEM, sterndrive type
HC5330	BA125-8EMV, sterndrive type
HC5331	92VPS, sterndrive type
HC5332	BA135-7EM, sterndrive type

STROKE	VOLUME	TORQUE 1000psi-70 BAR-35°
7" (178mm)	7.2 cu.in. (118.0 cc)	5024 in/lbs (58Kg)
7" (178mm)	8.2 cu.in. (134.4 cc)	5741 in/lbs (66Kg)
7" (178mm)	10.2 cu.in. (167.1 cc)	7117 in/lbs (82Kg)
7" (178mm)	10.2 cu.in. (167.1 cc)	7117 in/lbs (82Kg)
7" (178mm)	10.2 cu.in. (167.1 cc)	7117 in/lbs (82Kg)
7" (178mm)	13.7 cu.in. (224.5 cc)	9569 in/lbs (110Kg)
9" (229mm)	13.1 cu.in. (214.7 cc)	9375 in/lbs (108Kg)
9" (229mm)	13.1 cu.in. (214.7 cc)	9375 in/lbs (108Kg)
9" (229mm)	13.1 cu.in. (214.7 cc)	9375 in/lbs (108Kg)
9" (229mm)	17.7 cu.in. (290.1 cc)	12600 in/lbs (145Kg)
9" (229mm)	17.7 cu.in. (290.1 cc)	12600 in/lbs (145Kg)
9" (229mm)	17.7 cu.in. (290.1 cc)	12600 in/lbs (145Kg)
7" (178mm)	10.2 cu.in. (167.1 cc)	7117 in/lbs (82Kg)
8" (203mm)	8.5 cu.in. (139.2 cc)	7000 in/lbs (81Kg)
8" (203mm)	8.5 cu.in. (139.2 cc)	5850 in/lbs (67Kg)
8" (203mm)	8.5 cu.in. (139.2 cc)	5850 in/lbs (67Kg)
8" (203mm)	8.5 cu.in. (139.2 cc)	5850 in/lbs (67Kg)
8" (203mm)	8.5 cu.in. (139.2 cc)	N/A (N/A)
7" (178mm)	8.2 cu.in. (134.4 cc)	5741 in/lbs (66Kg)

Fittings

Seastar cylinder and all other fittings are 3/8" compression type fittings. Threads are 9/16" x 24 extra fine. A brochure on all Seastar fittings is available from Teleflex Canada.

Seastar I, II Hose

- Seastar I, II hose inside diameter – 5/16" (8mm)
- Other recommended hose is Aeroquip 2651 or equivalent. Inside diameter should not be smaller than 5/16"

PARTS LIST

HC5312 (BA125-7ATM Cylinder)

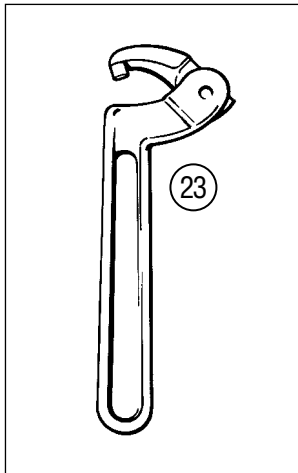
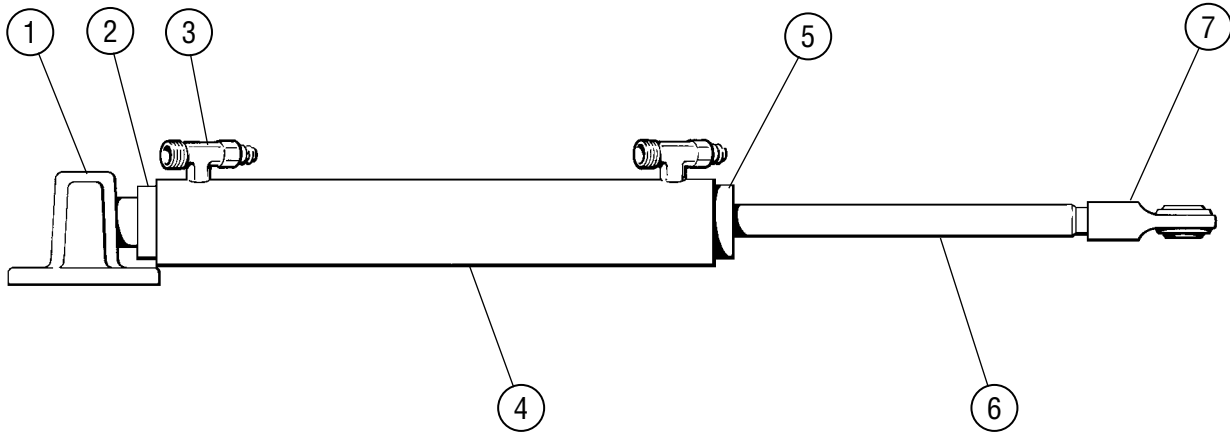

Figure 23

⚠ WARNING

When replacing any seals, make sure shaft is clear of any abrasions

ITEM	PART#	QTY	DESCRIPTION
1	HP5611	1	Trunnion Assembly
*2	371526	1	Gland Ball
3	HF5520	2	Bleed Tee 3/8" Tube
4	007921	1	Barrel
*5	008229	1	Gland End
6	320524	1	Piston/Shaft
7	292127	1	Rod End Ball
**23	N/A	1	Spanner Wrench

***NOTE**

When ordering items 2 & 5; order Seal Kit #HS5162

ITEM	PART#	QTY	DESCRIPTION
SEAL KIT # HS5154			
Seals Only			
SEAL KIT # HS5162			
2	371526	1	Gland Ball
5	008226	1	Gland End
**ITEM # 23 - SPANNER WRENCH			

3/16" C492 Proto Tool 3/4 - 2 Pin Wrench. Available at: Granger Distributors or, McMaster Carr Distributors Part # 5472A2 (www.mcmaster.com)

PARTS LIST

HC5313 (BA135-7ATM Cylinder)

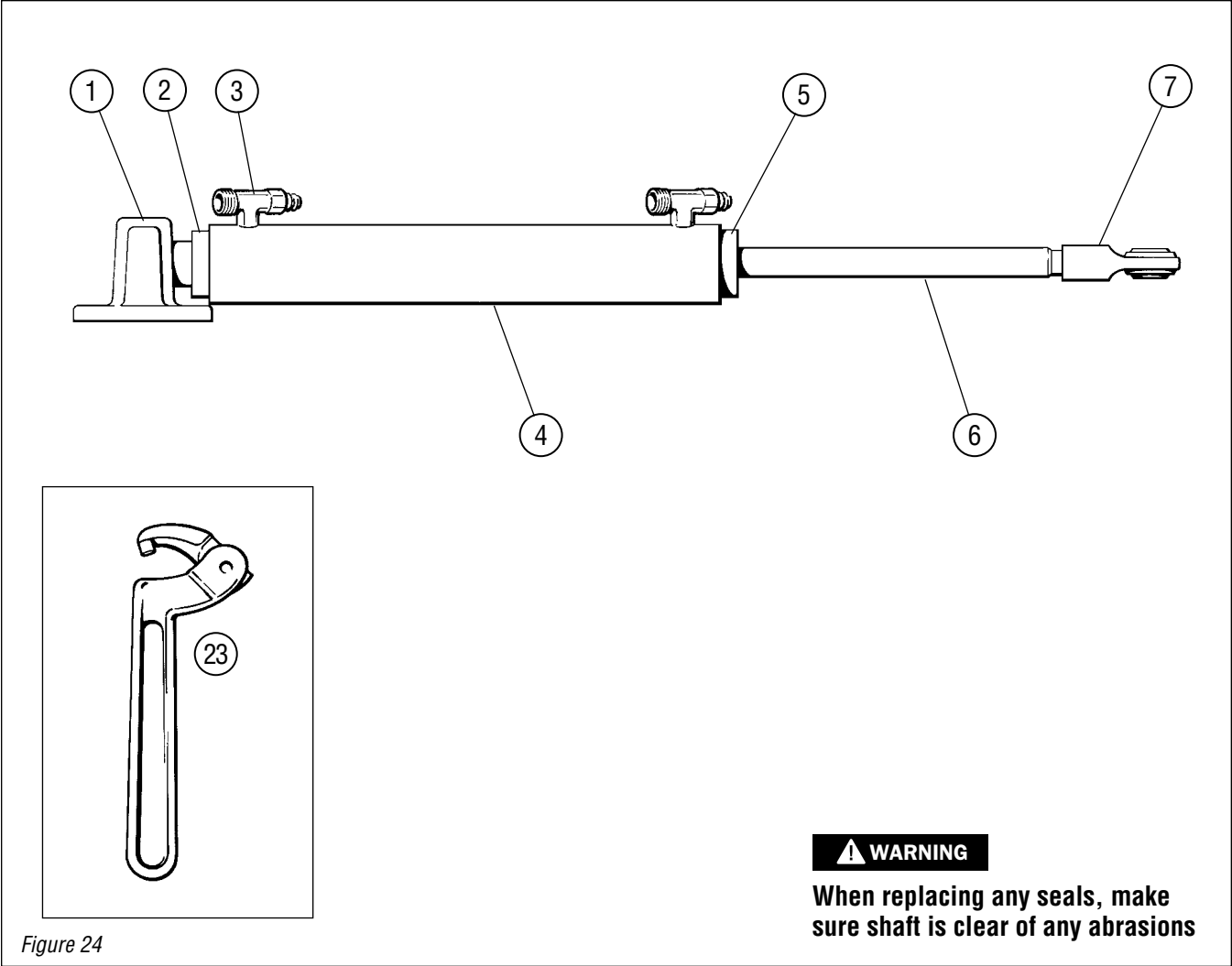

Figure 24

⚠ WARNING
 When replacing any seals, make sure shaft is clear of any abrasions

ITEM	PART#	QTY	DESCRIPTION
1	HP5611	1	Trunnion Assembly
*2	371620	1	Gland Ball
3	HF5520	2	Bleed Tee 3/8" Tube
4	062721	1	Barrel
*5	063122	1	Gland End
6	062825	1	Piston/Shaft
7	292127	1	Rod End Ball
**23	N/A	1	Spanner Wrench
*NOTE			
When ordering items 2 & 5; order Seal Kit #HS5163			

ITEM	PART#	QTY	DESCRIPTION
SEAL KIT # HS5155			
Seals Only			
SEAL KIT # HS5163			
2	371620	1	Gland Ball
5	063122	1	Gland End
**ITEM # 23 - SPANNER WRENCH			
3/16" C492 Proto Tool 3/4 - 2 Pin Wrench. Available at: Granger Distributors or, McMaster Carr Distributors Part # 5472A2 (www.mcmaster.com)			

PARTS LIST

HC5314 (BA150-7ATM Cylinder)

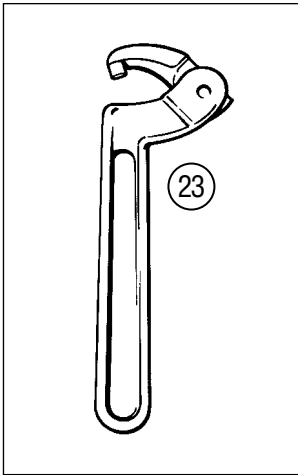
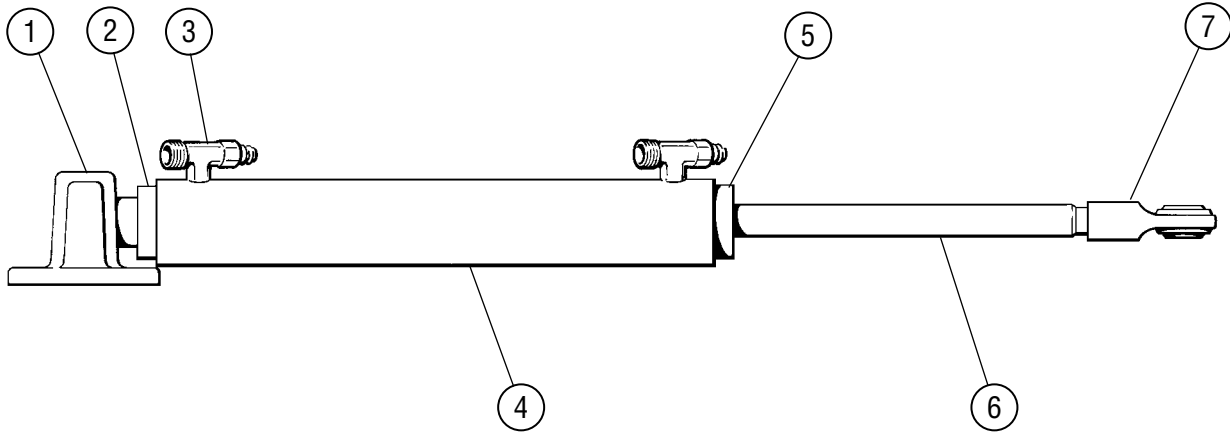

Figure 25

⚠ WARNING

When replacing any seals, make sure shaft is clear of any abrasions

ITEM	PART#	QTY	DESCRIPTION
1	HP5611	1	Trunnion Assembly
*2	371723	1	Gland Ball
3	HF5520	2	Bleed Tee 3/8" Tube
4	005324	1	Barrel
*5	005926	1	Gland End
6	020023	1	Piston/Shaft
7	292127	1	Rod End Ball
**23	N/A	1	Spanner Wrench

***NOTE**

When ordering items 2 & 5; order Seal Kit #HS5164

ITEM	PART#	QTY	DESCRIPTION
SEAL KIT # HS5156			
Seals Only			
SEAL KIT # HS5164			
2	371723	1	Gland Ball
5	005926	1	Gland End

****ITEM # 23 - SPANNER WRENCH**

3/16" C492 Proto Tool 3/4 - 2 Pin Wrench. Available at: Granger Distributors or, McMaster Carr Distributors Part # 5472A2 (www.mcmaster.com)

HC5318, HC5318-A*, HC5349 & HC5355 (BA150-7TM Cylinder)

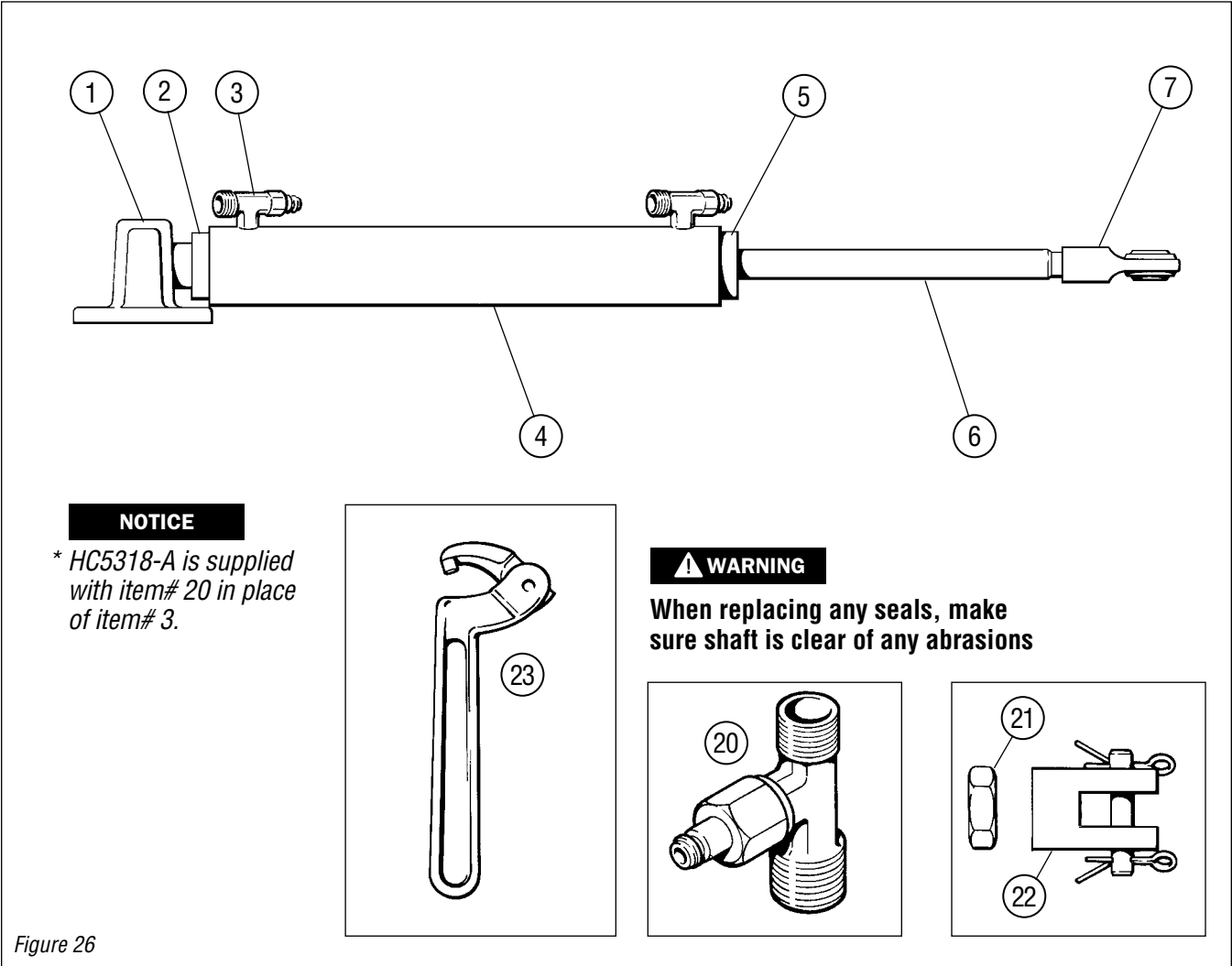

NOTICE

* HC5318-A is supplied with item# 20 in place of item# 3.

WARNING

When replacing any seals, make sure shaft is clear of any abrasions

Figure 26

ITEM	PART#	QTY	DESCRIPTION
1	135725	1	Trunnion Assembly
2	810828	1	Gland Ball
3	HF5519	2	Bleed Tee 1/2" Flare
4	136925	1	Barrel
5	137928	1	Gland End
6	139622	1	Piston/Shaft
7	560928	1	Rod End Ball
20	HF5518	2	Bleed Tee 3/8" Tube
21	003620	1	Jam Nut
22	HP5615	1	Clevis & Pin 5/8" x 5/8"
*23	N/A	1	Spanner Wrench

ITEM	PART#	QTY	DESCRIPTION
SEAL KIT # HS5182			
Seals Only			
*ITEM # 23 - SPANNER WRENCH			
3/16" C492 Proto Tool 3/4 - 2 Pin Wrench. Available at: Granger Distributors or, McMaster Carr Distributors Part # 5472A2 (www.mcmaster.com)			

PARTS LIST

HC5369, *HC5369HY & *HC5369HYC (BA150-7TM Cylinder)

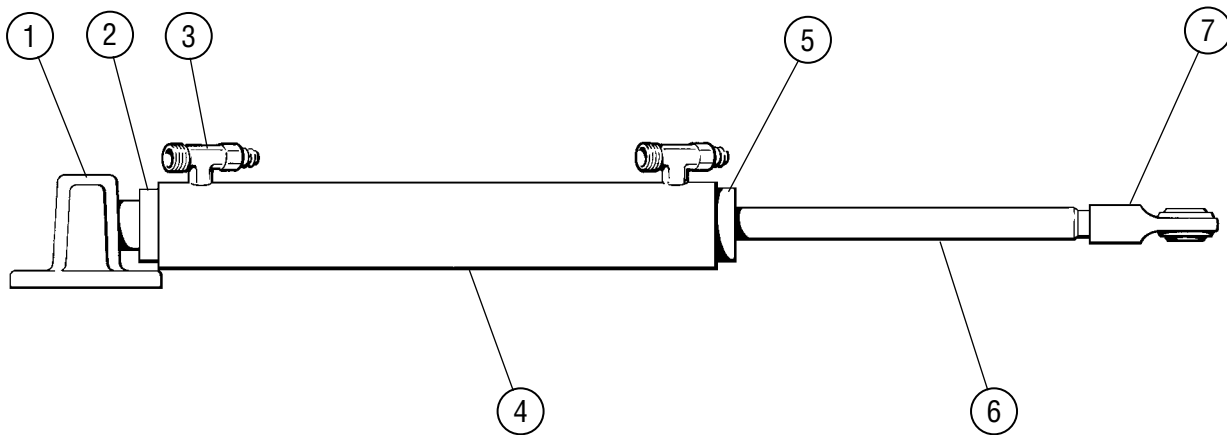

NOTICE

* Fittings are NOT supplied with HC5369HY or HC5369HYC and must be purchased separately.

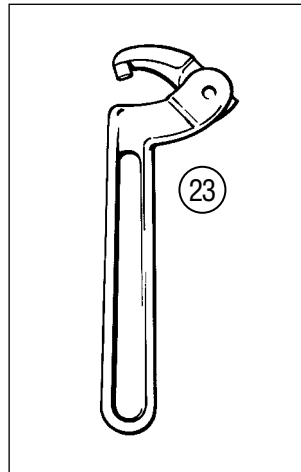

⚠ WARNING

When replacing any seals, make sure shaft is clear of any abrasions

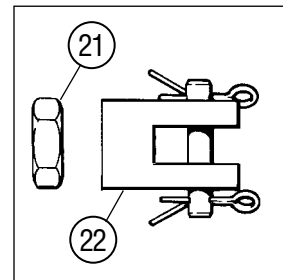
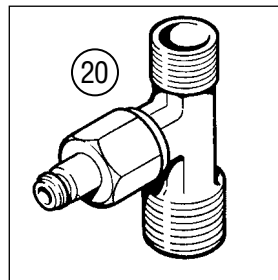

Figure 27

ITEM	PART#	QTY	DESCRIPTION
1	135725	1	Trunnion Assembly
2	810828	1	Gland Ball
3	HF5518	2	Bleed Tee 1/2" Flare (HC5369 Only)
4	836927	1	Barrel
5	137928	1	Gland End
6	839627	1	Piston/Shaft
7	560928	1	Rod End Ball
21	003620	1	Jam Nut
22	HP5615	1	Clevis & Pin 5/8" x 5/8"
**23	N/A	1	Spanner Wrench

ITEM	PART#	QTY	DESCRIPTION
SEAL KIT # HS5182			
Seals Only			
**ITEM # 23 - SPANNER WRENCH			
3/16" C492 Proto Tool 3/4 - 2 Pin Wrench. Available at: Granger Distributors or, McMaster Carr Distributors Part # 5472A2 (www.mcmaster.com)			

HC5319, HC5350 & HC5356 (BA175-7TM Cylinder)

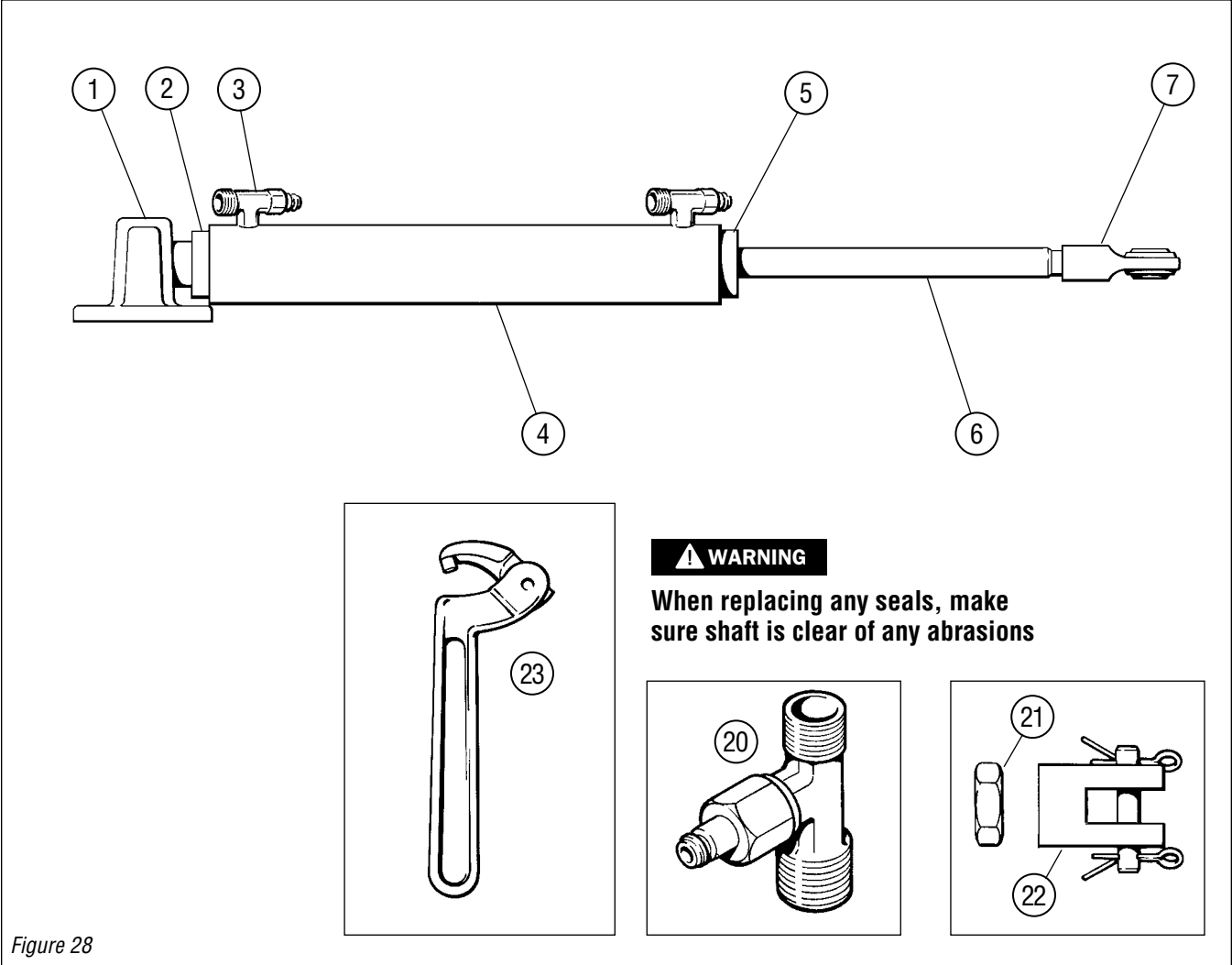

Figure 28

⚠ WARNING

When replacing any seals, make sure shaft is clear of any abrasions

ITEM	PART#	QTY	DESCRIPTION
1	135725	1	Trunnion Assembly
2	135227	1	Gland Ball
3	HF5519	2	Bleed Tee 1/2" Flare
4	135424	1	Barrel
5	135123	1	Gland End
6	135922	1	Piston/Shaft
7	560928	1	Rod End Ball
20	HF5518	2	Bleed Tee 3/8" Tube
21	003620	1	Jam Nut
22	HP5615	1	Clevis & Pin 5/8" x 5/8"
*23	N/A	1	Spanner Wrench

ITEM	PART#	QTY	DESCRIPTION
SEAL KIT # HS5183			
Seals Only			
*ITEM # 23 - SPANNER WRENCH			
3/16" C492 Proto Tool 3/4 - 2 Pin Wrench. Available at: Granger Distributors or, McMaster Carr Distributors Part # 5472A2 (www.mcmaster.com)			

PARTS LIST

HC5373, *HC5373HY & *HC5373HYC (BA175-9TM Cylinder)

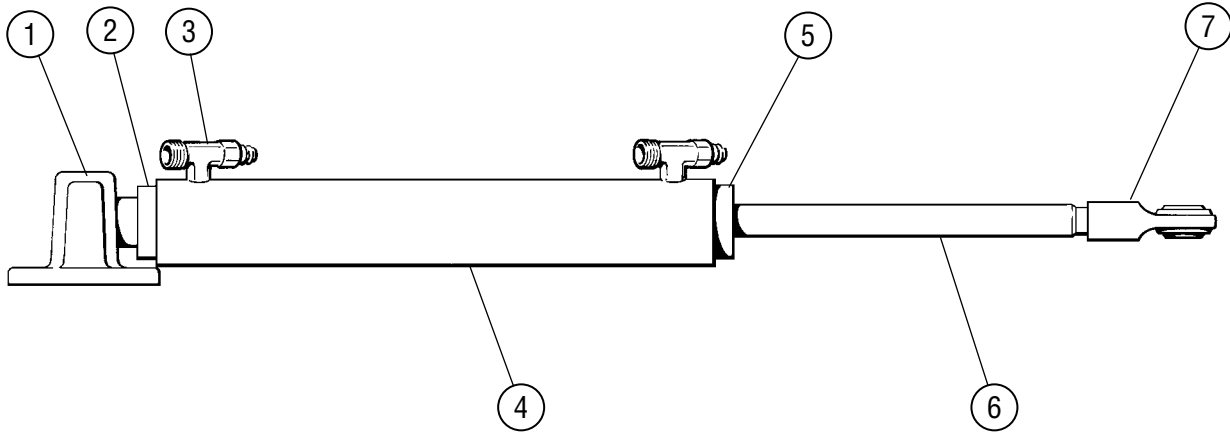

NOTICE

* Fittings are NOT supplied with HC5373HY or HC5373HYC and must be purchased separately.

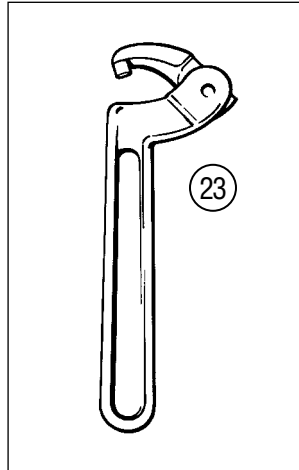

WARNING

When replacing any seals, make sure shaft is clear of any abrasions

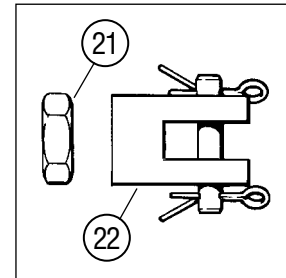
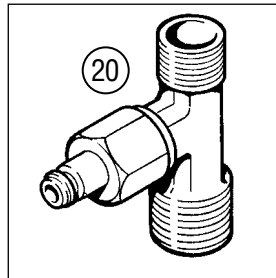
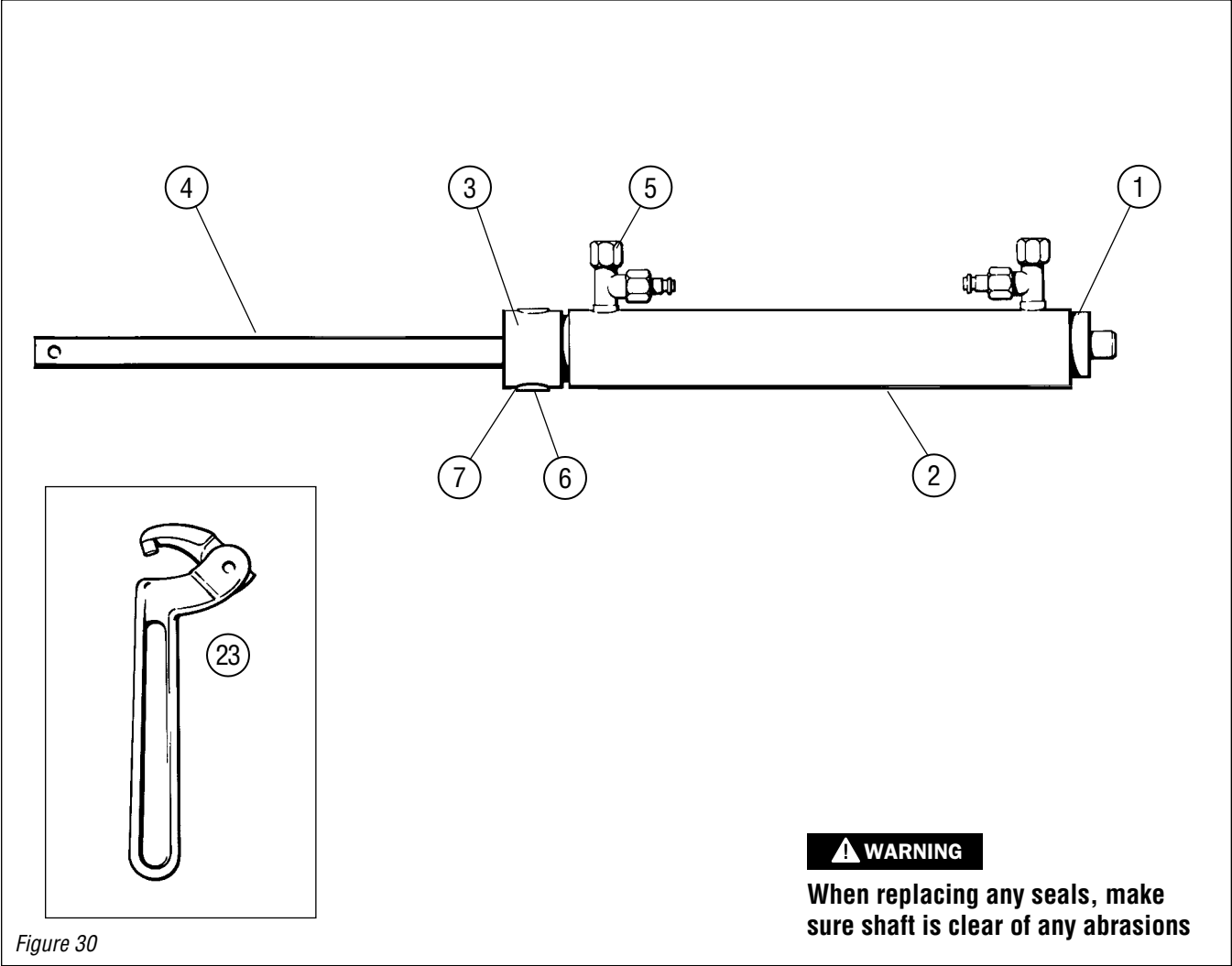

Figure 29

ITEM	PART#	QTY	DESCRIPTION
1	135725	1	Trunnion Assembly
2	135227	1	Gland Ball
3	HF5519	2	Bleed Tee 1/2" Flare (HC5373 Only)
4	135432	1	Barrel
5	135123	1	Gland End
6	135935	1	Piston/Shaft
7	560928	1	Rod End Ball (HC5373 & HC5373HY Only)
20	HF5518	2	Bleed Tee 3/8" Tube
21	003620	1	Jam Nut
22	HP5615	1	Clevis & Pin 5/8" x 5/8" (HC5373HYC Only)

ITEM	PART#	QTY	DESCRIPTION
**23	N/A	1	Spanner Wrench
SEAL KIT # HS5183			
Seals Only			
**ITEM # 23 - SPANNER WRENCH			
3/16" C492 Proto Tool 3/4 - 2 Pin Wrench. Available at: Granger Distributors or, McMaster Carr Distributors Part # 5472A2 (www.mcmaster.com)			

HC5326 (BA150-7EM Cylinder)



⚠ WARNING

When replacing any seals, make sure shaft is clear of any abrasions

Figure 30

ITEM	PART#	QTY	DESCRIPTION
*1	005926	1	Gland End
2	005324	1	Barrel
*3	377429	1	Gland Trunnion
4	377221	1	Piston/Shaft
5	409827	2	Bleed Tee Assembly
6	319921	2	Bushing
7	319724	2	Shim
**23	N/A	1	Spanner Wrench

***NOTE**

When ordering items 1 or 3 add 1ea. 006628 Oilite Bushing

ITEM	PART#	QTY	DESCRIPTION

SEAL KIT # HS5156

Seals Only

****ITEM # 23 - SPANNER WRENCH**

3/16" C492 Proto Tool 3/4 - 2 Pin Wrench. Available at: Granger Distributors or, McMaster Carr Distributors Part # 5472A2 (www.mcmaster.com)

PARTS LIST

HC5328 (125-8EM Cylinder)

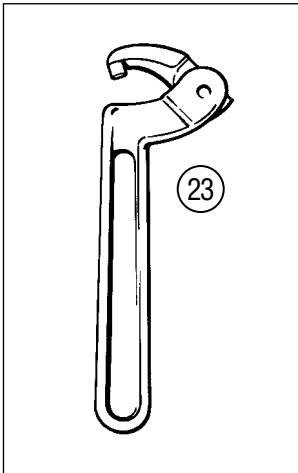
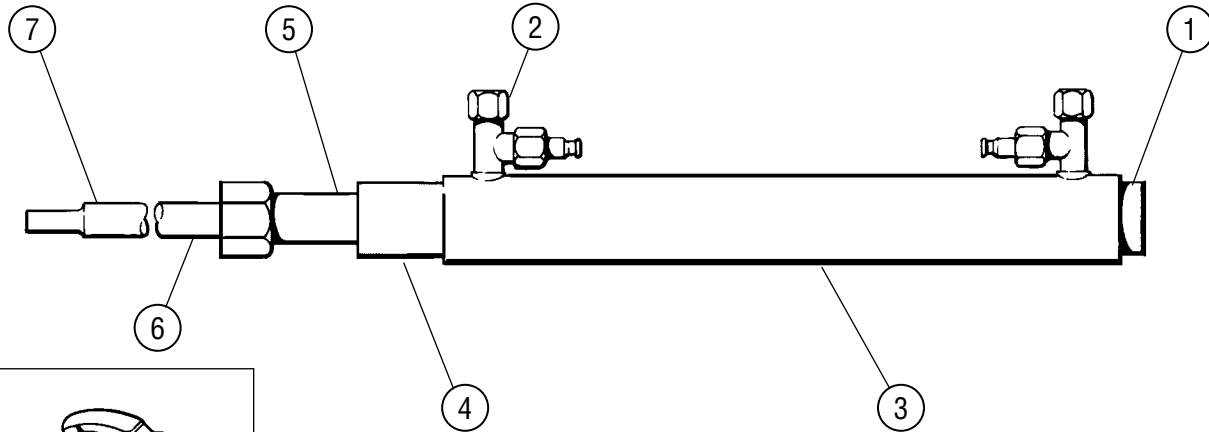

Figure 31

⚠ WARNING

When replacing any seals, make sure shaft is clear of any abrasions

ITEM	PART#	QTY	DESCRIPTION
*1	008229	1	Gland End
2	409827	2	Bleed Tee Assembly
3	379829	1	Barrel
*4	008322	1	Gland Merc
5	565029	1	Extension Tube
6	121121	1	Piston/Shaft
7	008426	1	Extension Rod
**23	N/A	1	Spanner Wrench

***NOTE**

When ordering items 1 or 4 add 1ea. 008623 Oilite Bushing

ITEM	PART#	QTY	DESCRIPTION
SEAL KIT # HS5154			
Seals Only			
**ITEM # 23 - SPANNER WRENCH			

3/16" C492 Proto Tool 3/4 - 2 Pin Wrench. Available at: Granger Distributors or, McMaster Carr Distributors Part # 5472A2 (www.mcmaster.com)

PARTS LIST

HC5329 (125-8VPEM Cylinder)

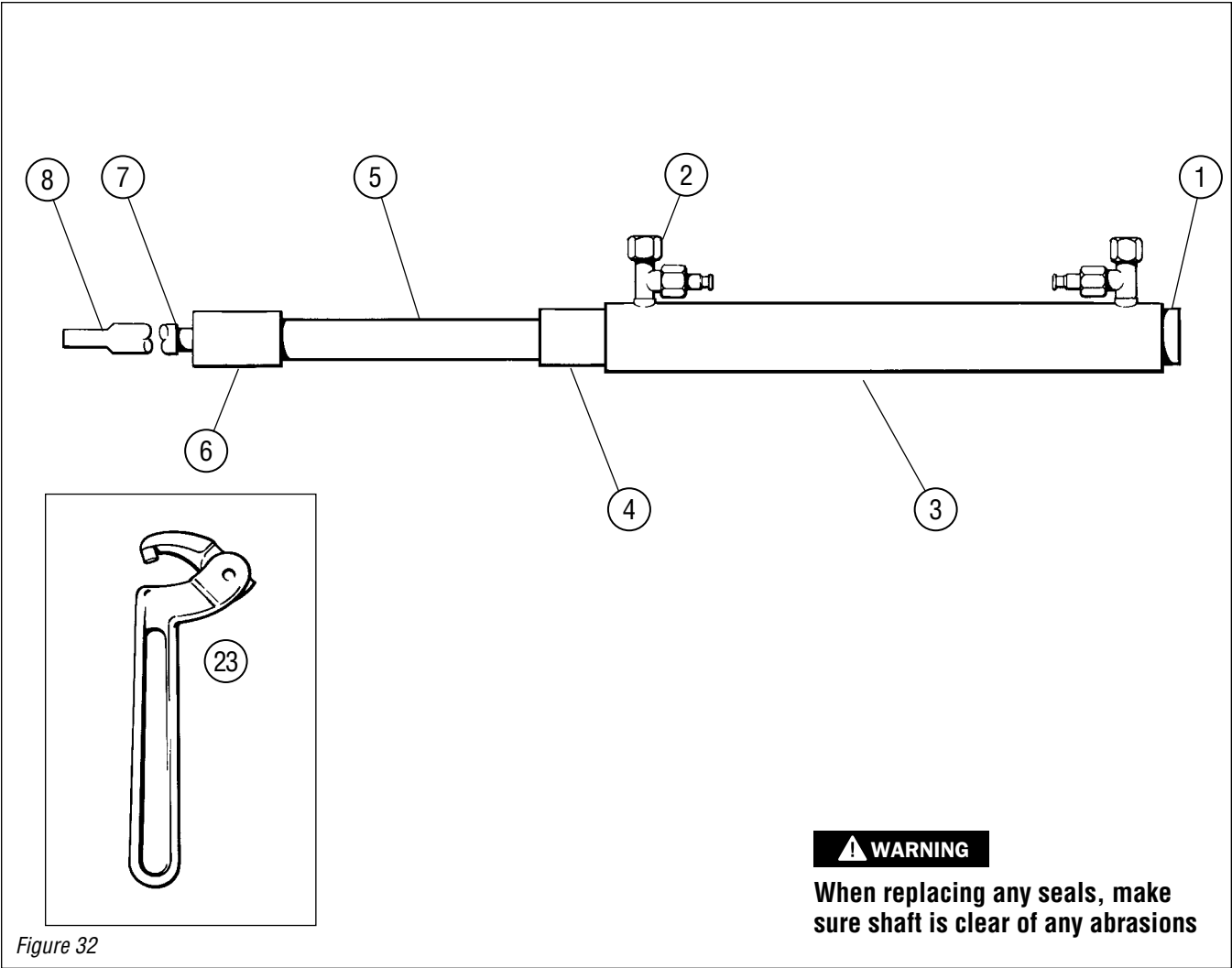

⚠ WARNING

When replacing any seals, make sure shaft is clear of any abrasions

Figure 32

ITEM	PART#	QTY	DESCRIPTION
*1	379922	1	Gland End
2	409827	2	Bleed Tee Assembly
3	379829	1	Barrel
*4	008322	1	Gland Merc
5	445720	1	Tube Support
6	445626	1	Bushing Screw
7	121121	1	Piston/Shaft
8	445429	1	Extension Rod
**23	N/A	1	Spanner Wrench
*NOTE			
When ordering items 1 or 4 add 1ea. 006623 Oilite Bushing			

ITEM	PART#	QTY	DESCRIPTION
SEAL KIT # HS5154			
Seals Only			
**ITEM # 23 - SPANNER WRENCH			
3/16" C492 Proto Tool 3/4 - 2 Pin Wrench. Available at: Granger Distributors or, McMaster Carr Distributors Part # 5472A2 (www.mcmaster.com)			

PARTS LIST

HC5330 (BA125-8VPEM Cylinder)

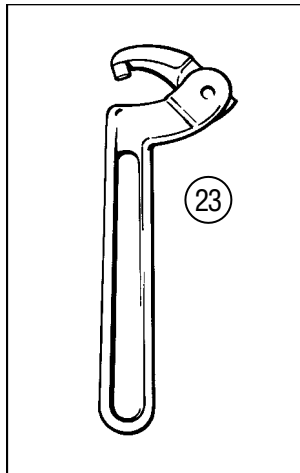
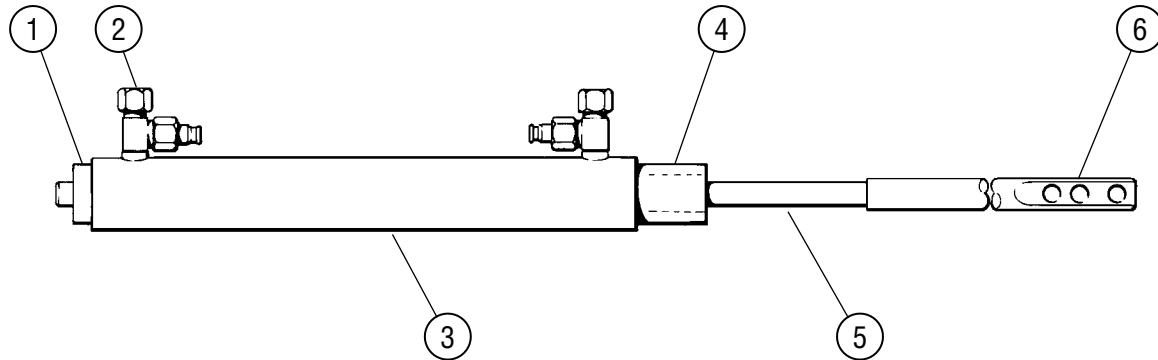

⚠ WARNING

When replacing any seals, make sure shaft is clear of any abrasions

Figure 33

ITEM	PART#	QTY	DESCRIPTION
*1	008229	1	Gland End
2	409827	2	Bleed Tee Assembly
3	379829	1	Barrel
*4	008322	1	Gland Merc
5	321527	1	Piston/Shaft
6	321621	1	Extension Rod
**23	N/A	1	Spanner Wrench

***NOTE**
When ordering items 1 or 4 add 1ea. 008623 Oilite Bushing

ITEM	PART#	QTY	DESCRIPTION
SEAL KIT # HS5154			
Seals Only			
**ITEM # 23 - SPANNER WRENCH			
3/16" C492 Proto Tool 3/4 - 2 Pin Wrench. Available at: Granger Distributors or, McMaster Carr Distributors Part # 5472A2 (www.mcmaster.com)			

PARTS LIST

HC5331 92VPS (1992–To date)

Figure 34

CAUTION

Cut Clevis Pin item 11 p.n. 562923 to a length of 2" when using the KAD 42-41 transom shields.

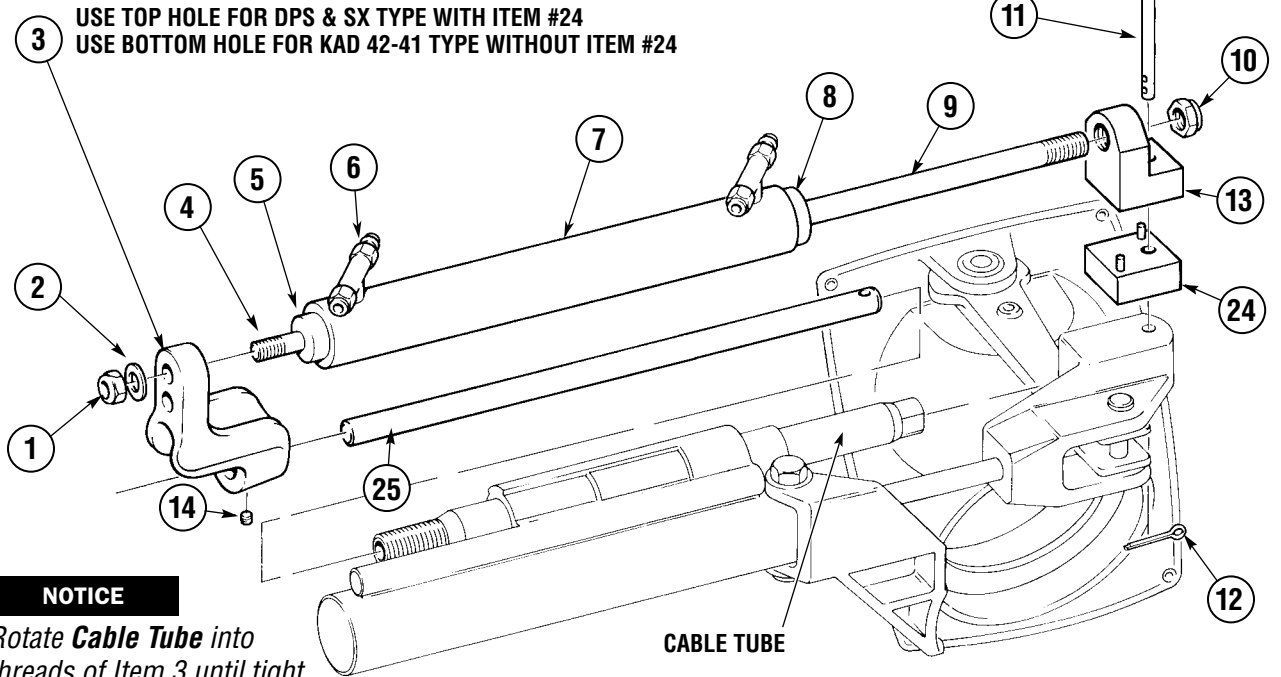

NOTICE

Rotate **Cable Tube** into threads of Item 3 until tight.

NOTICE

Item 11 must pass through Items 13, 24 and 25 before being secured by Item 12.

WARNING

When replacing any seals, make sure shaft is clear of any abrasions.

ITEM	PART#	QTY	DESCRIPTION
1	731720	1	Nut 7/16" NF
2	731625	1	Washer 7/16"
3	562820	1	Bracket Support
4	562726	1	Mounting Stud
*5	562622	1	Gland End
6	HF5520	2	Bleed Tee
7	379829	1	Barrel
*8	008229	1	Gland End
9	563023	1	Piston/Shaft

***NOTE**
When ordering items 5 or 8 add 1ea. 006623 Oilite Bushing

ITEM	PART#	QTY	DESCRIPTION
10	192624	1	Nut 1/2" NF
11	562923	1	Clevis Pin
12	020926	1	Cotter Pin
13	563127	1	Clevis Block
14	184721	1	Set Screw #10
24	963721	1	Spacer (DPS & SX only)
25	321446	1	Support Rod

SEAL KIT # HS5155
Seals Only

PARTS LIST

HC5327 (BA135-8EM Cylinder)

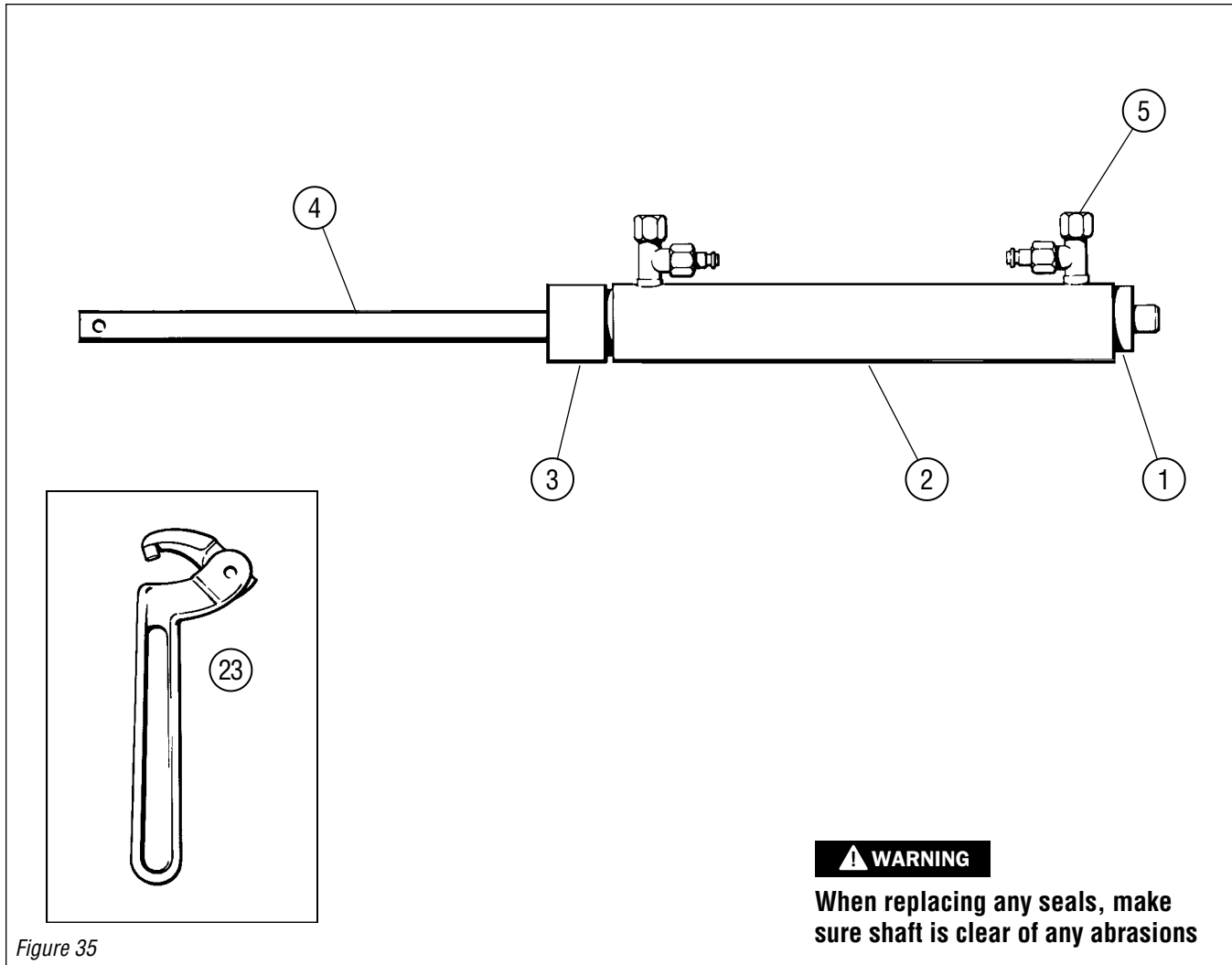

Figure 35

⚠ WARNING

When replacing any seals, make sure shaft is clear of any abrasions

ITEM	PART#	QTY	DESCRIPTION
*1	063029	1	Gland End
2	379227	1	Barrel
*3	063122	1	Gland End
4	379123	1	Piston/Shaft
5	409827	2	Bleed Tee Assembly
**23	N/A	1	Spanner Wrench

***NOTE**
When ordering items 1 or 3 add 1ea. 006628 Oilite Bushing

ITEM	PART#	QTY	DESCRIPTION
SEAL KIT # HS5155			
Seal Kit 135EM, MV, ATM			
**ITEM # 23 - SPANNER WRENCH			
3/16" C492 Proto Tool 3/4 - 2 Pin Wrench. Available at: Granger Distributors or, McMaster Carr Distributors Part # 5472A2 (www.mcmaster.com)			

HC5332 (BA135-7EM Cylinder)

NOTICE

Item# 7. Bushing used for Volvo SX Drives. Built by Volvo USA with 1/2" threaded tiller connection points.

NOTICE

If engine outdrive is NOT equipped with a torque tab on the underside of the lower leg, one must be installed to reduce prop torque.

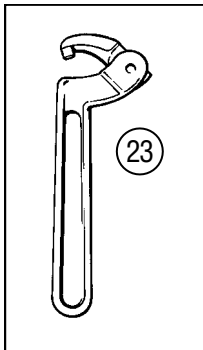
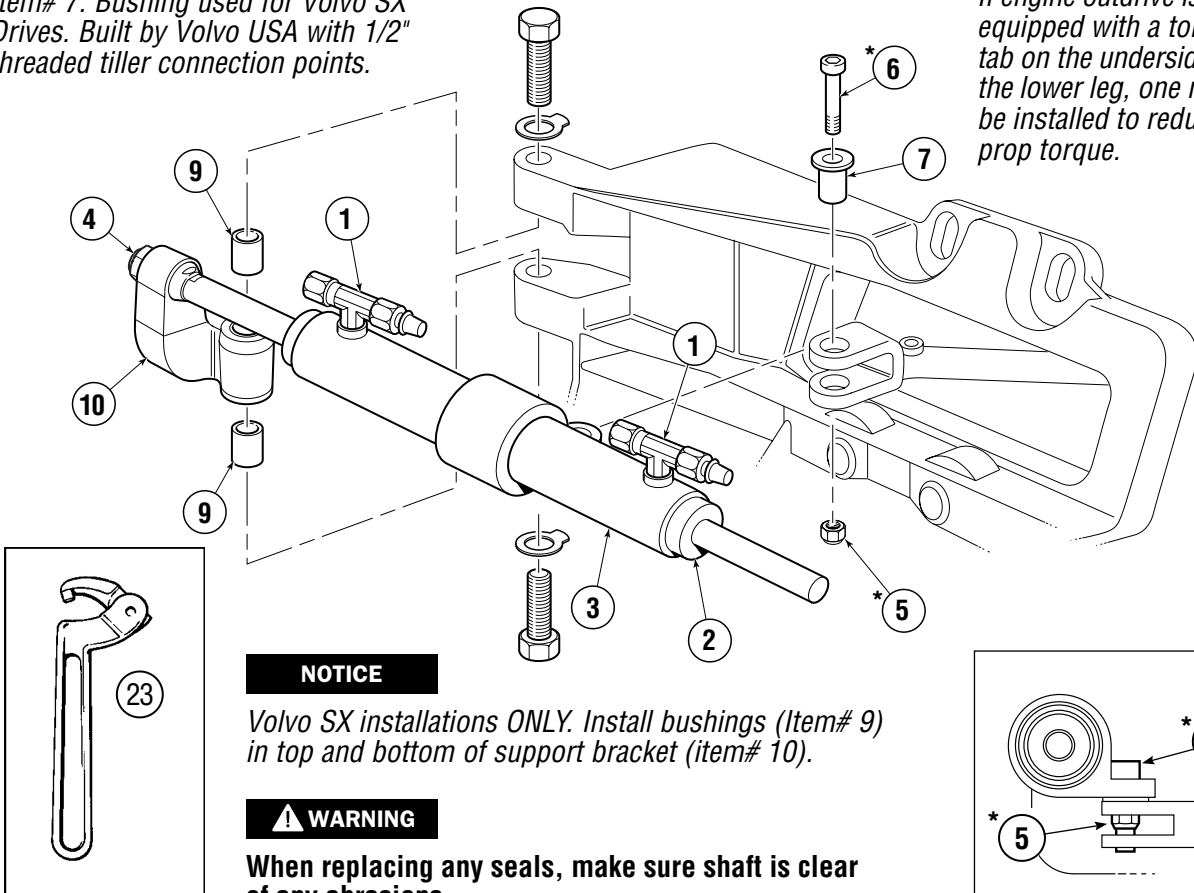

Figure 36

NOTICE

Volvo SX installations ONLY. Install bushings (Item# 9) in top and bottom of support bracket (item# 10).

WARNING

When replacing any seals, make sure shaft is clear of any abrasions

ITEM	PART#	QTY	DESCRIPTION
1	409620	2	Bleed Tee Assembly
2	063122	2	Gland End
3	062722	1	Barrel
4	192126	1	1/2" NF Nylok®, Ni/Pl, Brass
*5	113529	1	3/8" NF Nylok® Thin SS
*6	545503	1	SHCS, 3/8" NF x 1-1/2" SS

***NOTE**

Item 5 part number 113529 must be installed between Clevis Forks
Apply Item 7 p/n 373221 Locite® 242 to threaded portion of item 6 p/n 545503 before threading into item 5 p/n 113529

ITEM	PART#	QTY	DESCRIPTION
7	833657	1	HC5332 Volvo Adapter Bushing
*8	373221	1	Locite® 242 .5ml (.02 oz)
9	833658	2	Bushing, Volvo (Support Bracket)
10	833654	1	Support Bracket
**23	N/A	1	Spanner Wrench

SEAL KIT # HS5155

****ITEM # 23 - SPANNER WRENCH**

3/16" C492 Proto Tool 3/4 - 2 Pin Wrench. Available at: Granger Distributors or, McMaster Carr Distributors Part # 5472A2 (www.mcmaster.com)

Statement of Limited Warranty

We warrant to the original retail purchaser that **Teleflex Canada Limited Partnership** products have been manufactured free from defects in materials and workmanship. This warranty is effective for two years from date of purchase, excepting that where **Teleflex Canada Limited Partnership** products are used commercially or in any rental or income producing activity, then this warranty is limited to one year from the date of purchase.

We will provide replacement product without charge, for any **Teleflex Canada Limited Partnership** product not meeting this warranty, which is returned (freight prepaid) within the warranty period to the dealer from whom such product were purchased, or to us at the appropriate address. In such a case **Teleflex Canada Limited Partnership** products found to be defective and covered by this warranty, will be replaced at **Teleflex's** option, and returned to the customer.

The above quoted statement is an extract from the complete **Teleflex Canada Limited Partnership** products warranty statement. A complete warranty policy is available in our **Teleflex Canada Limited Partnership** products catalogue.

Return Goods Procedure

Prior to returning product to **Teleflex Canada Limited Partnership** under warranty, please obtain a *Return Goods Authorization number* (claim number).

Be sure to label the goods with:

- a) the name and address of the sender, and
- b) the return goods authorization number (claim number)

Please address the returned goods as follows:

From U.S.A.

RGA # ?
Teleflex Canada
c/o Panalpina
#8 – 14th Street
Blaine, WA 98230

From Canada

RGA # ?
Teleflex Canada
3831 No.6 Road
Richmond, B.C.
Canada V6V 1P6

